

Sublimation type retransfer printer

## EDISecure® Model XID5xxie Retransfer Printer

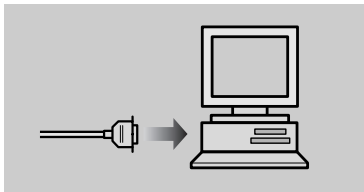

### Connection



See p.11~12,21

### Ink replacement

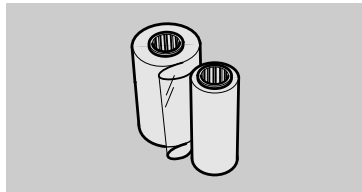

See p.14~18

### Setting the cards

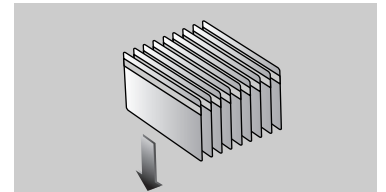

See p.18~20

### Operation and Setting the various modes

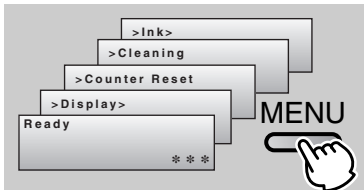

See p.25~39

### Care



See p.40~44

### Error codes

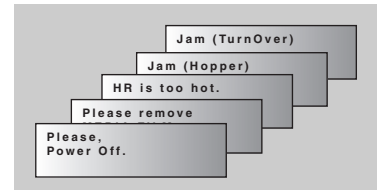

See p.46~47



- Thank for purchasing this product.
- **Please read this manual carefully** before use to ensure correct operation. **It is particularly important to read the Safety Precautions** for safe operation. After reading, retain this manual carefully for future reference.
- The product number is important for quality control. Upon purchase, check the back of the unit to make sure that the product number is correctly displayed.

#### Notes about this manual

- (1) This manual may not be reprinted in any way without permission.
- (2) The contents of this manual, as well as the specifications and design of this product, may change without notice.
- (3) The illustrations used in this manual may differ slightly from the actual product.

---

## Declaration of Conformity

Model Number: XIDie Printeryyyyy(y=A-Z,0-9 or blank)

Product name: Card Printer

We herewith declare that the above mentioned product complies with the following council directives and harmonized standards.

Council Directives: 1999/5/EC relating to radio equipment and telecommunications terminal equipment.

89/336/EEC relating to electromagnetic compatibility.

2006/95/EC relating to electrical equipment designed for use within certain voltage limits.

Harmonized Standards: EN55022:1998 Class B  
EN55024:1998+A1:2001+A2:2003  
EN61000-3-2:2000+A2:2005 Class A  
EN61000-3-3:1995+A1:2001+A2:2005  
EN60950-1:2001  
EN50371:2002  
EN300 330-2:V1.1.1  
EN301 489-03:V1.4.1

Manufacture:

Victor Company of Japan, Limited.  
2969-2, Ishikawa-cho, Hachioji-shi, Tokyo, 192-8620, Japan

Importer and distributor:

Digital Identification Solutions Group  
Teckstrasse 52 , 73734 Esslingen, Germany

Year to begin affixing CE Marking: 2005

Hachioji-shi, Oct, 2007

Place, Date

T. Nakama

Tsutomu Nakama Manager-Quality Control  
Victor Company of Japan, Limited.

---

## Information for USA

**NOTE:** This equipment has been tested and found to comply with the limits for a Class B digital device, pursuant to part 15 the FCC Rules. These limits are designed to provide reasonable protection against harmful interference in a residential installation. This equipment generates, uses and can radiate radio frequency energy and, if not installed and used in accordance with the instructions, may cause harmful interference to radio communications. However, there is no guarantee that interference will not occur in a particular installation. If this equipment does cause harmful interference to radio or television reception, which can be determined by turning the equipment off and on, the user is encouraged to try to correct the interference by one or more of the following measures:

- Reorient or relocate the receiving antenna.
- Increase the separation between the equipment and receiver.
- Connect the equipment into an outlet on a circuit different from that to which the receiver is connected.
- Consult the dealer or an experienced radio/TV technician for help.

**Caution:** Changes or modifications not approved by party responsible for compliance could void user's authority to operate the equipment.

## Information for Canada

Operation is subject to the following two conditions:  
(1) this device may not cause interference, and (2) this device must accept any interference, including interference that may cause undesired operation of the device.

## Information for EU



Machine noise  
Sound power level: less than 70dB(A) according to DIN45635 part 19 (EN27779).  
The measurements are to be made according to DIN45635 part 2019 or EN27779, respectively.

# Contents

Notes for safe operation .....	5	LCD operation display content .....	24
Before use .....	7	Operation .....	25
Product features .....	7	Turning on the power .....	25
Checking accessories .....	7	Turning off the power .....	26
Handling of transfer film, ink ribbons and cards ....	7	About the RESET button .....	26
Handling .....	7	On Initialization when the retransfer film cassette	
Storage .....	7	and/or the ink ribbon cassette is loaded .....	26
Storing and handling cards after printing .....	8	User modes .....	27
Purchasing print media and cards .....	8	User mode screen flow .....	27
Escape Clause .....	8	User mode settings.....	28
Installation .....	9	Display mode settings .....	29
Installation diagram .....	9	Clearing the free counter .....	30
Names of parts .....	10	Cleaning mode .....	30
Front.....	10	Ink mode setting .....	32
Rear .....	10	Retransfer mode setting .....	33
When the printer door is open .....	10	Buzzer mode setting .....	34
Set-up .....	11	Power saving mode settings.....	34
Connecting the IC unit (sold separately) .....	11	Setting the bend remedy mode .....	35
Medium-type IC unit and Compact IC unit (sold		Card Thickness setting mode .....	36
separately) .....	11	Coercivity setting mode .....	36
Connecting the Laminator .....	11	Non-contact IC antenna setting mode .....	36
Connecting the power cord.....	12	IC contact setting mode .....	36
Installing the card stacker .....	13	Test print .....	36
Discharging the card .....	13	Unit No. setting .....	36
Setting the ink ribbon .....	14	Network setting .....	37
Setting the retransfer film .....	16	Input method for Address setting mode .....	39
Caution when loading the retransfer film cassette		Low temperature stand-by mode setting .....	39
and/or the ink ribbon cassette .....	18	Download mode .....	39
Setting cards.....	18	Transport mode .....	39
Inserting cards .....	18	Care and cleaning .....	40
When using magnetic cards.....	20	Cleaning the cleaning rollers .....	40
When using contact IC cards .....	20	Cleaning the thermal head .....	41
Loading cards .....	20	Cleaning the fan filter .....	41
Switching the card thickness.....	20	Cleaning the card feed rollers and heat rollers....	42
Connecting with a host computer .....	21	Cleaning the magnetic head .....	43
USB cable connection .....	21	Cleaning of the bobbin holders .....	44
LAN cable connection .....	21	Once printer servicing and cleaning have been	
Connecting Multiple Printers .....	22	completed .....	44
The copyright of the software is displayed .....	22	Periodical maintenance .....	44
Before use .....	23	Troubleshooting.....	45
Names of parts on the operation panel .....	23	Layout of rollers inside the printer .....	45
Setting buttons .....	23	Error code listing.....	46
Operation display LED .....	23	Stopping when printing .....	48
LCD panel .....	23	Mending broken ink ribbon and retransfer film ....	48
Operation display LED contents and the LCD panel ...	24	About printing errors .....	48
Initialization period .....	24	When retransfer operation is not complete .....	48
Preheating period.....	24	Caution when printing characters .....	48
		Removing card jams .....	49
		Hopper jam .....	49
		Turnover section [Jam (turnover)] .....	50
		Retransfer section [Jam (transfer)] .....	50
		Specifications .....	51
		Main specifications .....	51
		In case of disposal .....	52

## Before you use

Read these notes on safety thoroughly before operating your printer in order to use the unit properly. Once you start using the unit, this manual should be put aside the unit, or at a convenient place where you can look up the manual any time as you need.

### WARNING

■ If you ignore the warning with this mark, and handle the unit in a wrong way, death or serious injuries may occur.

### CAUTION

■ If you ignore the caution with this mark, and handle the unit in a wrong way, injuries or damages to properties may occur.

### WARNING

■ If the abnormal phenomena as listed below are seen, immediately stop operating the unit. Continuing operation may cause a fire or electric shock.

- Smoke or odd smell comes out from the machine.
- Water or metal went into the machine.
- The unit fell to the floor, or the cabinet was broken.
- The power cable is damaged (exposed lead, broken cable, etc.)

If you see these phenomena, turn off the power, pull out the power plug, and contact your dealer as soon as possible. Do not try to repair it by yourself. It is dangerous.

■ Do not remove the screws, or disassemble or alter the machine.

- High-voltage components are contained in the unit. Touching these areas may result in an electric shock.
- Ask your dealer if you want your printer inspected or repaired.
- Do not remove the external covers of the machine. You may get an electric shock.

■ Do not work on the power cable, or give excessive force on it. Do not put heavy objects such as furniture on the cable.

- The cable may be damaged, causing a fire or electric shock.
- When you find a defect on the power cable, such as exposed lead, stop using the unit, and consult your dealer.

■ Do not use the machine with the power plug inserted incompletely.

- The machine generates heat due to incomplete contact, causing a fire or electric shock.
- Do not put many cords on a single plug socket. The power cords also heats up.

■ Do not use the machine with dusts piled on the power plug. Do not put a metallic material adjacent to the power plug.

- Dusts and metal are conductive, causing a fire or electric shock.
- Pull out the power plug from the outlet every six months, and clean the dusts piled on the legs and body of the plug.

■ Do not use a line voltage other than instructed.

- Using a line voltage or power supply which is not specified may cause a fire or electric shock.

■ Do not put foreign materials from the openings of the machine (e.g., vents, card slots, cassette inlet, etc.)

- Metals, flammable things, and other foreign materials may cause a fire or electric shock if entering into the machine.
- If these things went into the machine, immediately turn off the power, pull out the power plug, and ask your dealer to repair. Do not try to repair it by yourself. It is dangerous.

■ Do not put a container with liquid in it, or small metal ornaments and the like on the machine.

- The liquid or metal entering into the machine acts as a conductor, causing a fire or electric shock.
- If liquid or metal went into the machine, immediately turn off the power, pull out the power plug, and ask your dealer to repair. Do not try to repair it by yourself. It is dangerous.

■ Do not place the machine on a rickety table or slanting places.

- The machine may fall out of the table or fall over, which may damage the machine or injure you.
- If the machine is damaged by falling or turnover, immediately turn off the power, pull out the power plug, and ask your dealer to repair. Do not try to repair it by yourself. It is dangerous.

■ Do not wet the machine with water.

- Using the machine at a place where water splashes on the machine, or wetting the machine with water (applying, throwing, or spilling water over the machine) may cause a fire or electric shock.
- If water entered into the machine, immediately turn off the power, pull out the power plug, and ask your dealer to repair. Do not try to repair it by yourself. It is dangerous.

■ Do not touch the machine with wet hands.

- Touching the machine with wet hands may cause an electric shock.

■ Do not touch the power plug during electrical storms.

- Lightning may cause an electric shock.

## Notes for safe operation (continued)

- Ground the machine with the attached electric cord when connecting it to the utility outlet.
- Using a cord other than the one supplied for grounding may cause an electric shock when the machine fails.
- Do not put your head or yourself into the packaging bag.
- Do not play with the packaging bag. You may suffocate yourself.
- Give close attention to small children who may want to play with the packaging bag.
- Do not use the machine while it has a fault.
- Do not use the machine while it has a fault, as this may cause a fire or electric shock.
- Immediately turn off the power, pull out the power plug, and ask your dealer to repair. Do not try to repair it by yourself. It is dangerous.
- Do not use the power supply code of the attachment excluding this machine. It may cause a fire or electric shock.



## CAUTION

- Pull out the power plug before cleaning the machine.
- This is for preventing electric shocks.
- Pull out the power plug when you won't use the machine for a prolonged period of time to assure safety.
- Remove the power plug from the outlet for safety when you won't use the machine for a long time.
- Do not move the machine with the power cable and other electric cables connected.
- The cables may be damaged while being moved, which may cause a fire or electric shock.
- You may stumble over the cable and get injured.
- Do not move the machine with objects placed on it.
- They may fall on you and hurt you.
- Do not put heavy objects on the machine.
- They may fall on you and hurt you.
- Do not block the vents.
- Heat generated inside the machine cannot escape, which may cause a fire.
- Be sure to work with two persons when you unpack, move or lift the machine.
- If you work alone, you may be injured by the fallen machine or hurt your back by lifting a heavy machine by yourself.
- Inspection
- Ask your dealer or a qualified person to inspect the machine, typically once every two to three years. Operating the machine with dusts piling on the components for a prolonged period of time may cause a fire or a malfunction of the machine. It will be particularly effective to inspect the machine before wet rainy season. Consult your dealer on the costs of inspection.
- Do not put the machine at a place where it will be wet with steam (e.g., from a humidifier), or at an excessively humid or dusty place.
- The oil, water and dusts act as conductors, which may cause a fire or electric shock.
- Do not put the machine at a place where it becomes excessively hot.
- The surface and internal components may deteriorate. Also there is a danger of a fire. Special care should be taken for exposure to direct sunlight or a heater adjacent to the machine.
- Hold the body of the power plug when pulling it out.
- Do not pull out the plug by holding the cable. The cable may be broken or damaged which may in turn cause a fire or electric shock.
- Do not touch the power plug with a wet hand
- You may get an electric shock.
- Do not lay the power cable near the heating equipment.
- The covering of the cable will melt due to heat from such equipment, which may cause a fire or electric shock.
- The heat rollers and adjacent areas become hot during operation.
- Be careful not to touch the heat rollers and adjacent areas when replacing the ink ribbon or retransfer film, or remove jammed cards.
- Wait until the heat rollers get cooled down to prevent burns.
- Be careful of jamming your hand or fingers in the card tray, card bracket on the hopper, or printer door.
- Replace the ink ribbon or retransfer film, or remove jammed cards with care not to jam your hand or fingers in the mechanism, which may cause an injury.
- Do not use a power cable other than the specified cable for connection.
- If you use an unspecified power cable for connection or extension, heat may accumulate in the cable, causing a fire.

## Product features

- This card printer allows printing of high-quality, full color images equivalent to photographic quality onto standard size (ISO 7810 compliance) plastic cards using sublimation type transfer printing.
- Use of sublimation type retransfer printing enables printing of cards other than those made of PVC and non-contact IC cards, etc. with uneven surfaces that were previously difficult to print directly.  
(Some card materials may not be suitable for printing. Consult your dealer regarding the materials to be used and specifications required before purchase.)
- Printing with no margins on all sides is possible.
- This printer have more securer erase function (security erase) to protect of the individual information.
- The host interface utilizes USB mode and Ethernet mode.
- This printer can automatically discern what type of ink ribbon is installed by means of RF-ID tag built inside.

## Checking accessories

Please check for any missing accessories when opening the box.

- AC 120V type(For North America) . . . . . 1 unit
- AC 200V type(For Europe) . . . . . 1 unit
- Instruction manual : English . . . . . 1 unit
- \* The detached power cords and the Instruction manual vary according to model and country of purchase.
- Cleaning card : 1 unit
- Card stacker : 1 unit
- Ink ribbon cassette : 1 unit
- Retransfer film : 1 unit cassette
- USB Cable (200cm) : 1 unit
- Jog lever (inside the card tray) : 1 unit
- Gloves : 1 unit

## Handling of transfer film, ink ribbons and cards

### Handling

Take note of the following points when handling print media (retransfer film and ink ribbons) and cards.

- Use of bent or damaged cards may result in card feed error.
- Do not touch the print media or the printed surface of cards directly with the hands as this may cause blurring of the print.
- Foreign materials on the printing area may result in misprints. Always load the print media and cards in a clean environment.
- Static build-up in the print media or cards can cause errors. To avoid causing static electricity, do not rub cards together.
- When replacing or replenishing print media or cards that have been stored at low temperature, let the print media or cards sit for at least one hour at the same temperature as location where the printer is to be used before use. Using print media or cards as they are may cause condensation and result in malfunction or print errors.

### Storage

The storage condition of the print media (retransfer film and ink ribbons) and cards may have a strong influence on the print quality. Select a storage location that fits the following criteria:

Storage environment  
Storage temperature : 5°C to 25°C

Storage environment relative humidity : 40% to 60%

Storage location  
To avoid deterioration of the ink ribbon and retransfer film, do not store in the following locations:

- Locations exposed to direct sunlight
- Locations with high temperature and high humidity
- Locations near organic solvents or diazo copiers.

Storage period  
Print media should be used within a half year of purchase. For cards, please consult the dealer from which they are purchased.

## Before use (continued)

### Storing and handling cards after printing

Avoid storing the cards in locations exposed to direct sunlight or with high temperature and high humidity. Furthermore, avoid contact with the following chemicals and stationery, as they can cause discoloration or fading of the cards:

- Organic solvents such as alcohol, film cleaner, diazo copies, etc.
- Soft vinyl chlorides, document cases, pass holders, erasers, etc.
- Hair-dressing products and cosmetics, etc.

### Purchasing print media and cards

Contact your dealer regarding the purchase of print media (retransfer film and ink ribbons) and cards. Always use the products specified below.

#### Print media

Use only the ink ribbons and retransfer film specified for this unit. For the names of these products refer to "Main Specifications" on p. 51 of this manual.



#### CAUTION

We can accept no liability for any problems arising as a result of the use of media using materials other than those specified.

#### Card material

ISO/IEC 7810 type ID1 (dimensions) :  
equivalent product  
ISO/IEC 7811-2 (Magnetic stripe) :  
equivalent product  
ISO/IEC 7816 (IC card) :  
equivalent product

The materials of some cards may not be suitable for printing. Consult your dealer regarding the materials to be used and specifications required before purchase.

## Escape Clause

We do not provide compensation for any malfunction during card printing caused by breakdown of the machine, ink ribbon defects or card characteristics. In addition, we also do not provide compensation for insufficient print quality, which are not agreed in advance. Please evaluate carefully beforehand.

#### ● Card Material

Some card material may not be suitable for printing. Using a contact-type IC card other than those specified by the dealer, may cause damage to the thermal head. No compensation is made for the life reduction and failures that were caused by unsuitable card material. Warp of card or uneven thickness of IC cards, even though they are within the tolerance of JIS or ISO standards, may not be suitable for printing or feeding. For details on the specifications about card material or others, consult the dealer in advance

#### ● Version upgrade

The following defects may occur as a result of the version upgrade for the firmware of the printer or for the printer driver.

- Card printing is disabled for the application software that has been used.
- The operation of the printer or application software becomes unstable.
- Defects in print result occurs.
- Print color or shade differs.
- The performance of reproducing fine letters, changes.
- Others

Be sure to retain a copy of the current version when performing version upgrade. Reinstall the previous version immediately if these problems occur. We are not liable for any damage such as defective cards or interruptions during printing as a result of the version upgrade.

## Installation

The performance of the card printer is strongly influenced by the installation location. Be careful of the following items as for installation location.

- Install in the locations is not so much as to cause print defect due to dust adherence.  
Dusty environment increases print defect. It is recommended that the card printer is used in the locations with the cleanliness Class 8 or better of ISO14661-1. But at least avoid the following locations.  
(1) Carpeted room  
(2) Crowded locations  
(3) Locations where paper (corrugated etc.) is handled  
(4) Areas near copy machines  
When the card printer is not used, it is recommended that the power is turned off and the printer is covered by plastic sheet etc. (not textile).
- Install in the locations where the printer performance is kept.  
Avoid the locations below where the performance or life of the printer is affected.  
(1) Locations where there is vibrations or shock  
(2) Locations exposed to direct sunshine.  
(3) Wet locations without ventilation  
(4) Unstable locations and sloped surface  
(5) Areas near air conditioners, humidifiers, stoves, etc. that may cause condensation within the printer.
- Install in the environment that gives full play to the printer ability.

The printer is to be installed in an environment with the following temperature and humidity.

Temperature	:	15°C to 30°C
		59°F to 86°F
Humidity	:	35% to 70%



### CAUTION

Use of the printer in an environment with temperature lower than the above range may cause retransfer errors and use of the printer in an environment with temperature higher than the above range may cause print errors from deformation of the cards and wrinkling of the film.

### Installation diagram

Ventilation holes are provided for the cooling fan on the bottom and sides of the unit. Avoid inserting any object into the gap between the bottom of the unit and the top of the stand. Install the unit with its sides at least 20cm away from the surrounding wall as illustrated in the diagram, and keep the back of the unit at least 10cm away from the wall. Also, do not place any object on top of the unit.

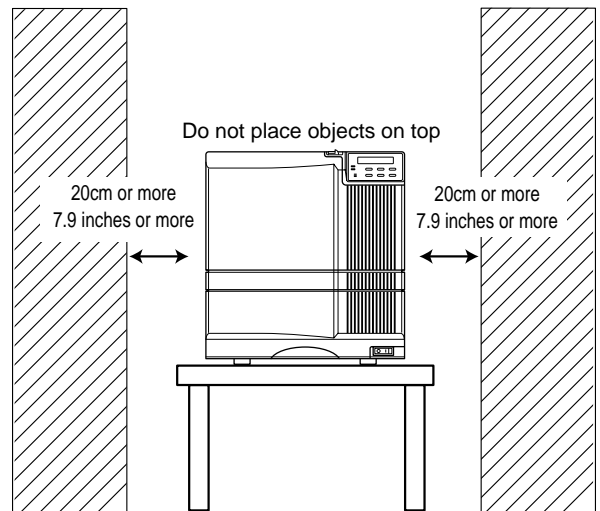

# Names of parts

Front

When the printer door is open

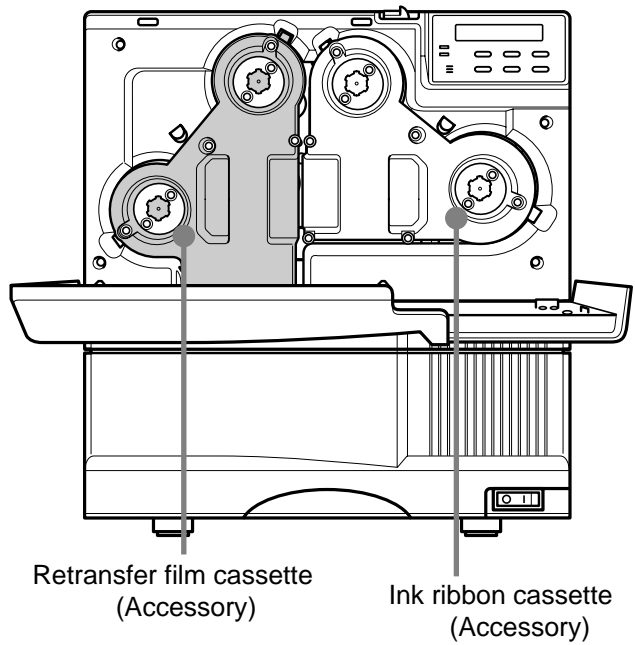
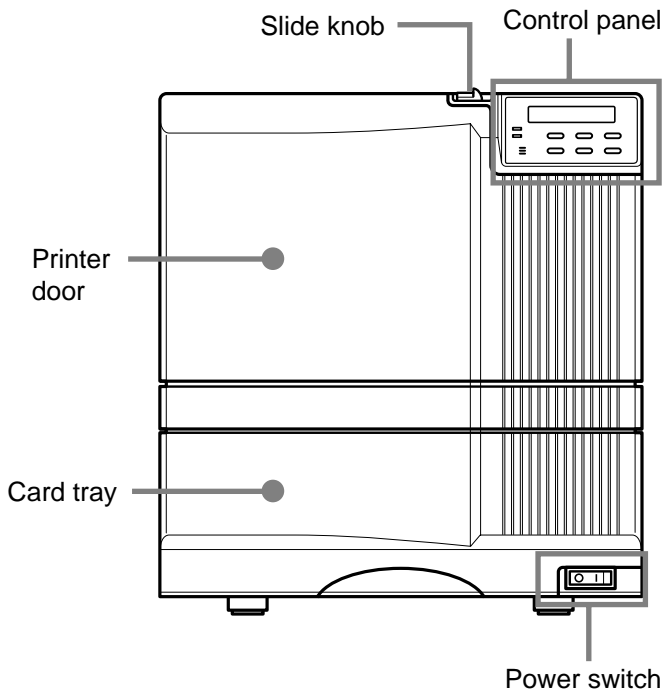

Rear

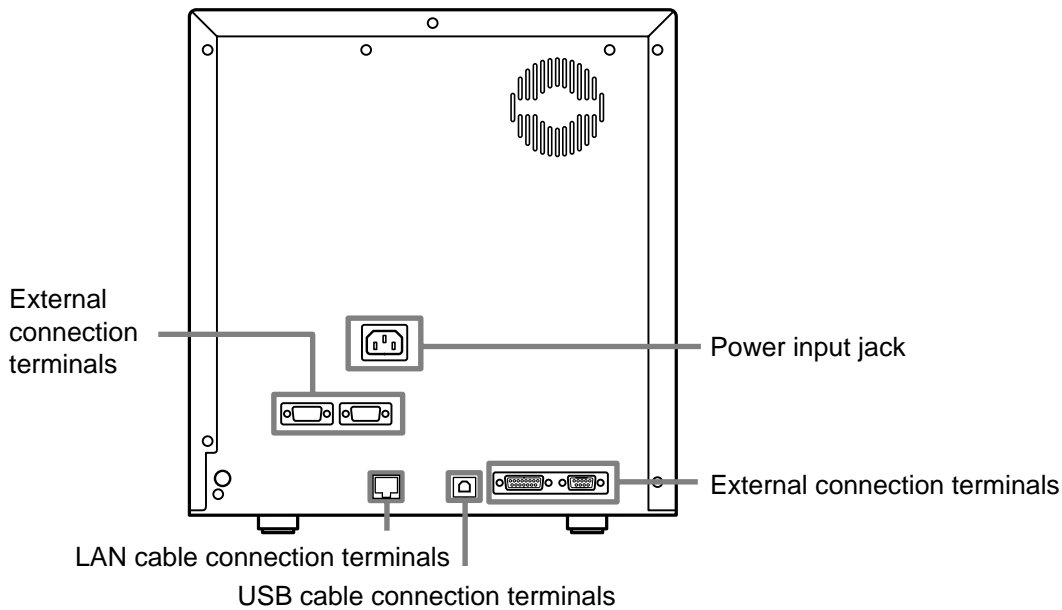

## Connecting the IC unit (sold separately)

Medium-type and compact size IC units are sold separately, as are specialized optional devices for the printer. Consult your dealer for more details.

### WARNING



- Make sure that the power switch is turned OFF and the AC cable is detached from the plug, before connecting and disconnecting the IC units. Otherwise electric shocks, fires or malfunction of the product may occur.
- Using IC units other than those specified may cause electric shocks, fires or malfunction of the product.

Medium-type IC unit and Compact IC unit (sold separately)

Please ask your dealer for the Compact IC unit connection.

Connect the compact IC unit to the host computer with the interface cables which are commercially available. The medium-type IC unit has various type of interface cable, according to installed IC unit. Consult your dealer for more details.

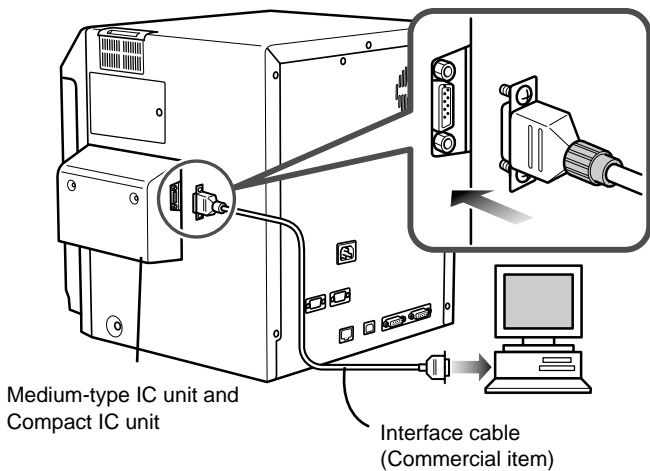

## Connecting the Laminator

The laminator is sold separately, as a specialized optional device for the printer. Consult your dealer for more details.

### WARNING



- Make sure that the power switch is turned OFF and the AC cable is detached from the plug, before connecting and disconnecting the laminator. Otherwise electric shocks, fires or malfunction of the product may occur.
- Using laminator other than those specified may cause electric shocks, fires or malfunction of the product.

1. Set up the unit joint plate which comes with the laminator (optional). Mount the printer on to joint plate.

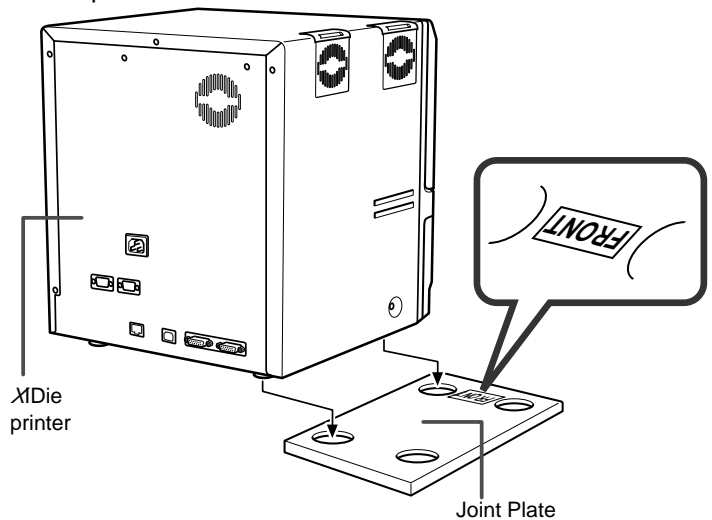

# Set-up (continued)



## CAUTION

Be careful not to pinch your finger when installing.

### 2. install the laminator

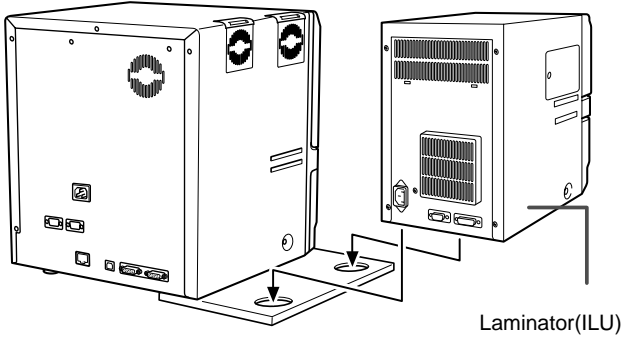

## Memo

If the mounting is uneven, the card would not be transported smoothly. be sure to fit the units right in. Always install the unit at a horizontal and hard surface location

### 3. Install the unit connecting cable.(optional)

As shown in the diagram, connect the cable to the OPTION 2 external connection terminal of the printer and the PRINTER external connection terminal of the laminator.

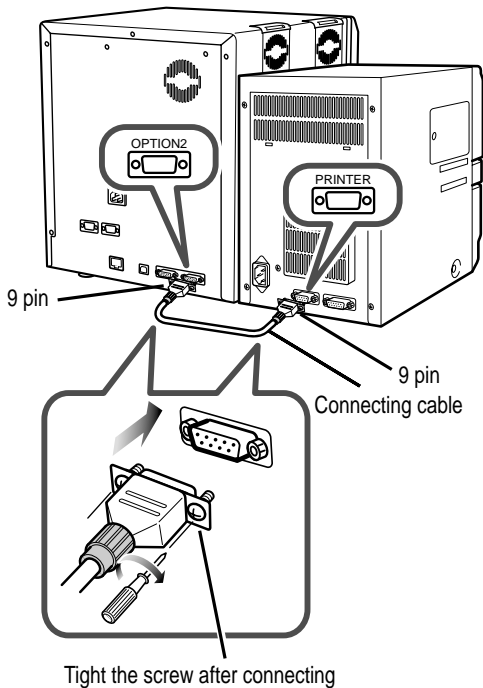

## CAUTION

Make sure to tighten the screws of the interface cables.

## Connecting the power cord

### 1. Check the plug.

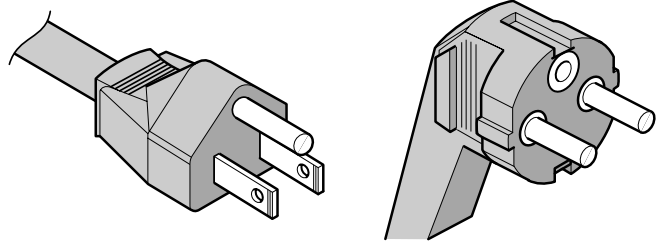

• For AC 120V type (North America)

• For AC220-240V type (Europe)

\* The detached power cords vary according to model and country of purchase.

### 2. Plug the power cable into the printer.

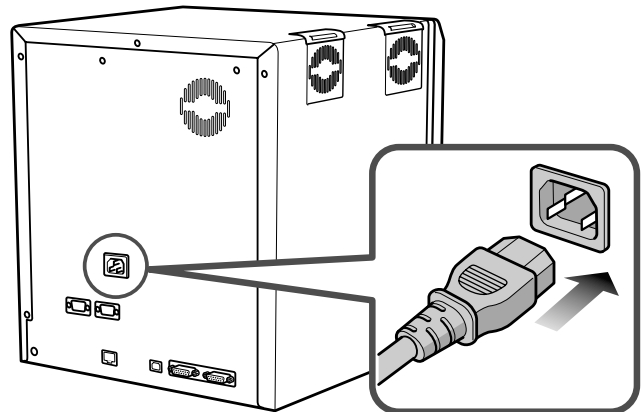

Plug the power cable of the laminator if it is installed.



## CAUTION

Always use a grounded power outlet. Never share the outlet with other electrical equipment.

Use an AVR (Automatic Voltage Regulator) if there is a possibility of voltage fluctuation. Use an uninterruptible power source rather than an AVR if there is the possibility of uninterruptible power source.

# Installing the card stacker

Hang the stacker claw on the stacker receptacle.

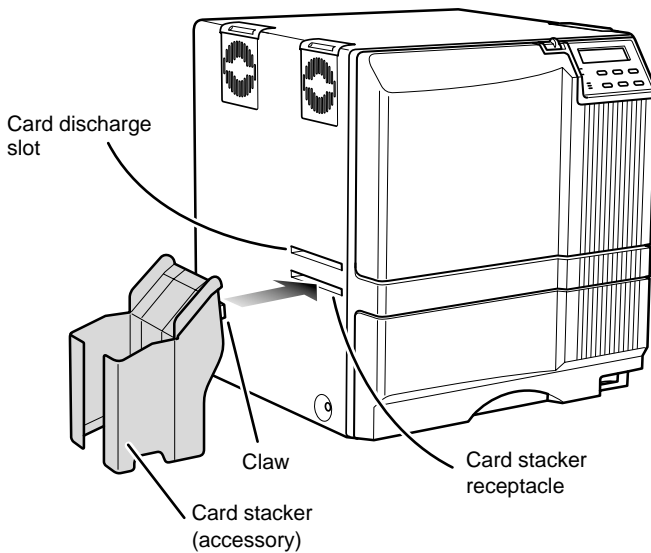

The card stacker is capable of containing approximately 100 0.76mm(0.03inches)-thick cards or 300 0.25mm (0.01inches)-thick cards at the maximum.

**CAUTION** Be sure to hang the card stacker claw on the card stacker receptacle, not the card discharge slot. If you mount the card stacker at a wrong place, cards are not discharged, resulting in a card jam.

When connecting the laminator, pull the tab of the card stacker at the stacker mount of the laminator card.

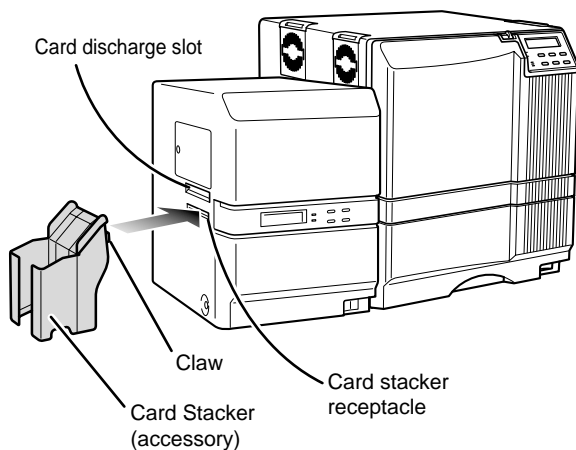

# Discharging the card

When correctly printed, the cards are discharged from the left side.

If a card jam or a write error on magnetic stripes occurs on the way, results differ depending on the areas.

Portion A: If a card jam, a write error on magnetic stripes or an IC unit encode error occurs on the way, press the RESET button, then the ENTER button. The printer is initialized, and the cards are discharged from the right side of the printer.

Portion B: See the description in Jam (Transfer) on p.50.

Portion C: When correctly printed, the cards are discharged from the left side of the printer. The cards jamming around this area are also discharged from the left side.

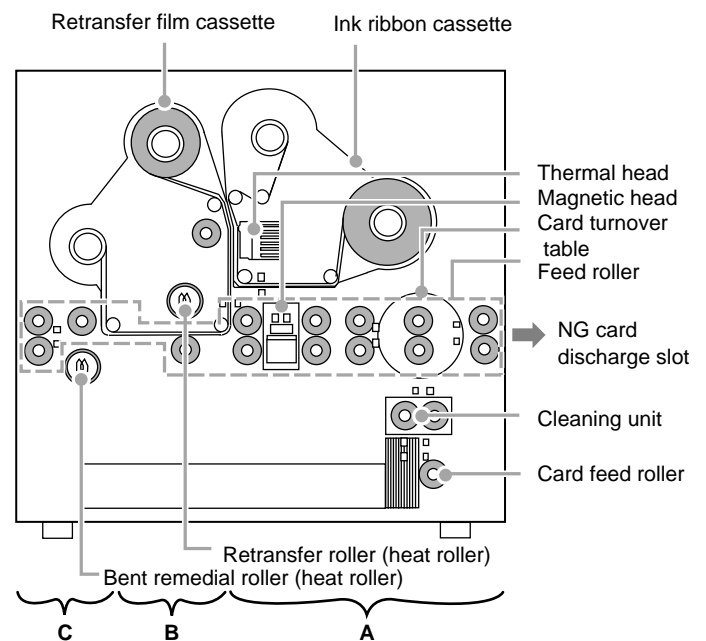

## Setting the ink ribbon



### CAUTION

Do not touch the surface of the ink ribbon with your hands.

### 1. Activate the slide knob and open the printer door.

When the slide knob is moved, the printer door opens downwards. Hold the door with your hand and open it slowly.

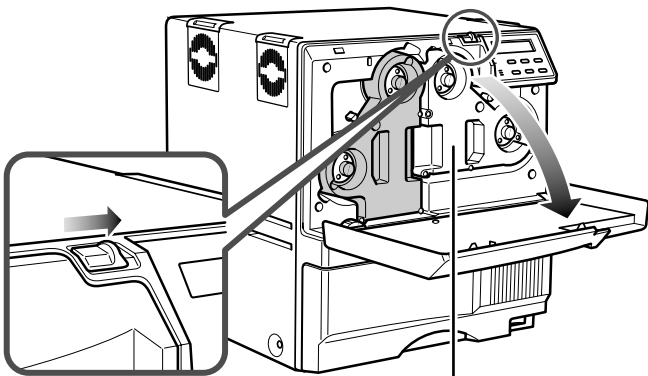

Ink ribbon cassette (Orange)



### CAUTION

Do not put the ink ribbon or retransfer film on the back of the door for mounting. Do not rest your elbows or put a heavy thing on the back of the door. The printer door may be broken.

### 2. Remove the ink ribbon cassette.

When the lever is pressed, a small portion of the cassette pops out.

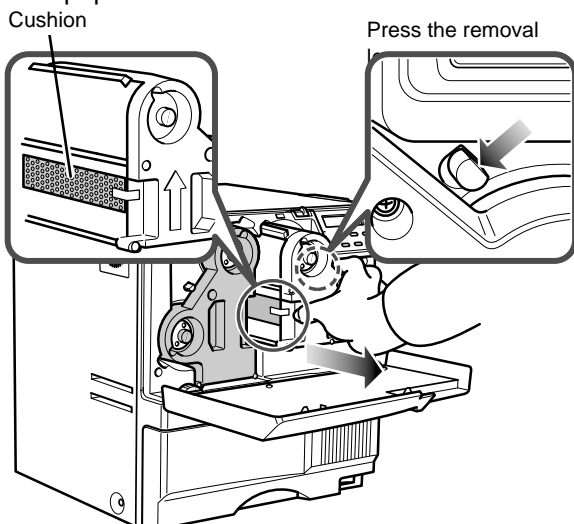

### CAUTION

When transporting the unit, remove the ink ribbon and the retransfer film, then place the cushion on the thermal head. Transporting without the cushion may cause the thermal head and roller to malfunction. Do not use cushion materials other than the transfer cushion that comes with the unit, as this may cause damage to the head.

### 3. Remove the head pad.

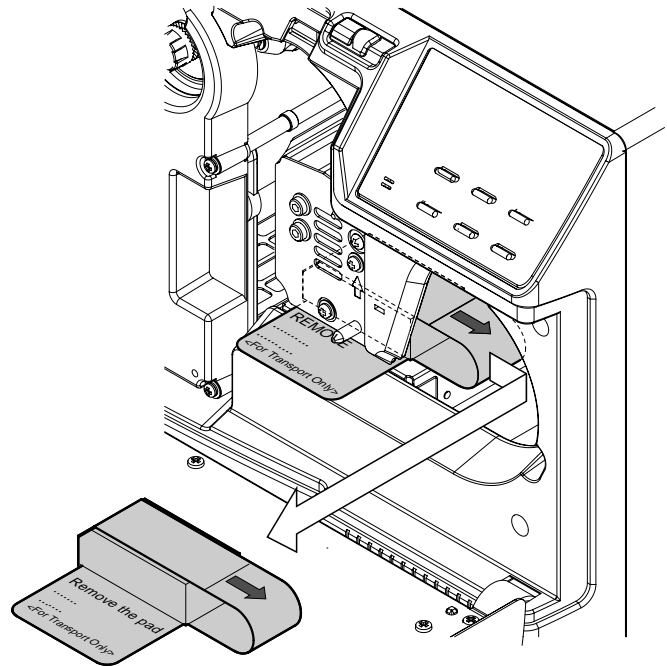

### CAUTION

When transporting the unit, then place the head pad on the thermal head.

### 4. Insert the ink ribbon into the cassette.

Stretch the ink ribbon along three shafts with the ink face of the ribbon facing outside and insert the bobbins firmly into the bobbin holders.

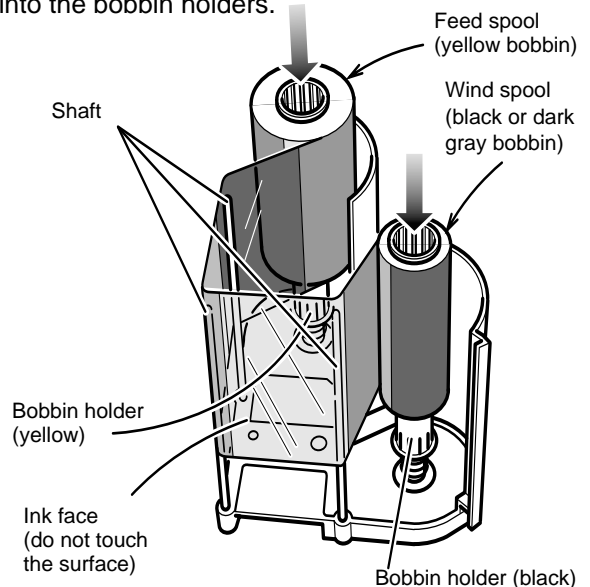

Place the cassette upright on a flat surface during set-up.



### CAUTION

When you need to take out the cassette, for instance, to clean the printer, be sure to put the cassette upright as shown in the above illustration. When the ink ribbon is put on the table with its face down, dusts attach to the surface, causing a malfunction of the printer.

### 5. Wind the ribbon, taking up the slack.

Turn the knob in the arrow direction to wind a small portion of the ink ribbon. If the ink ribbon does not wind up, go back to step 3, and insert the ink ribbon firmly into the bobbin holders.

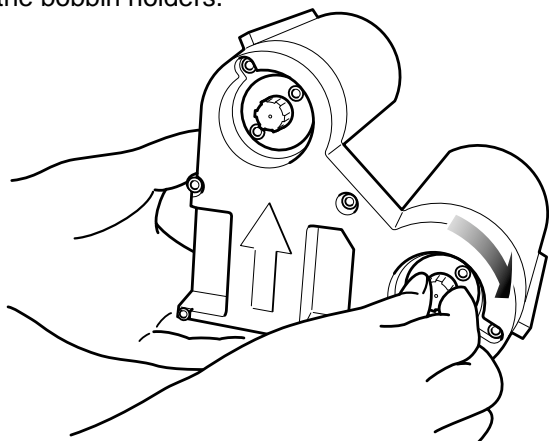

**CAUTION** If the ink ribbon is not tightly wound, the slack may cause the ribbon to be caught in the parts of the printer when you set the cassette, or the card to be printed in uneven colors.

### 6. Insert the cassette along the guide rail.

Insert the cassette until it clicks securely into position. The lever returns to its original position.

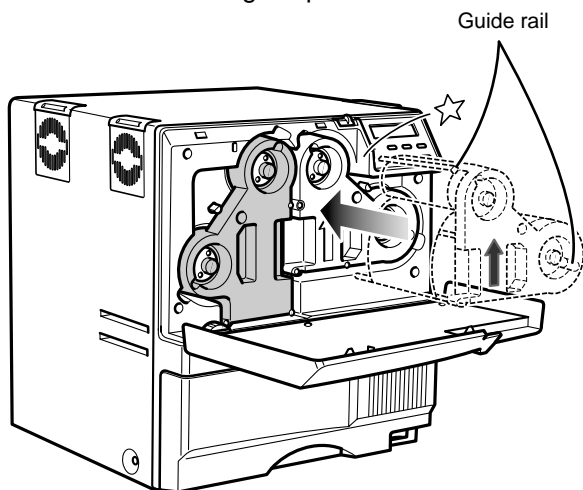

**CAUTION**

- The cassette containing the ink ribbon is heavy. Hold the cassette with both hands when you set or take out the cassette.
- If the cassette unit is not inserted until it clicks securely into position before printing, horizontal lines may be printed with the image.

### 7. Close the printer door.

If you want to mount the retransfer film, keep the door open and go to the next page.

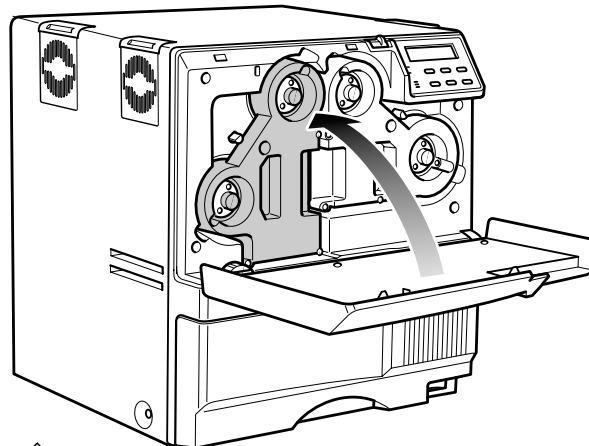

#### Memo

When the ink ribbon is wound up to the end,

**Ink Run Out**

appears on the LCD panel.

After replacement press the RESET button, then press the ENTER button.

If the ink ribbon is not set properly,

**Ink Search**

or

**Ink Broken**

appears on the LCD panel. When these messages are output, check:

- The ink ribbon is firmly inserted into the bobbin holders.
- The ink face of the ribbon is directed correctly.
- The feeding and winding bobbins are mounted correctly.

#### Memo

To mount the ink ribbon which is partially used, set the unused portion of the ribbon (yellow bobbin) on the bobbin holder indicated with an arrow on the seal of the cassette.

Printing with the ink ribbon set improperly may cause the image to be faint.

## Setting the retransfer film



### CAUTION

Do not touch the retransfer film surface with your hands.

### 1. Activate the slide knob and open the printer door.

When the slide knob is moved, the door opens downwards. Hold the door with your hand and open it slowly.

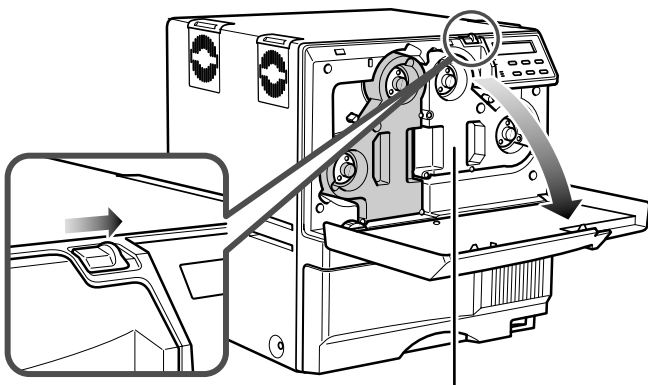

Retransfer film cassette (yellowish green)



### CAUTION

Do not put the ink ribbon or retransfer film on the back of the door for mounting. Do not rest your elbows or put any heavy object on the back of the door as it may break.

### 2. Remove the retransfer film cassette.

When you press the lever, a small portion of the cassette pops out.

Press the cassette removal lever.

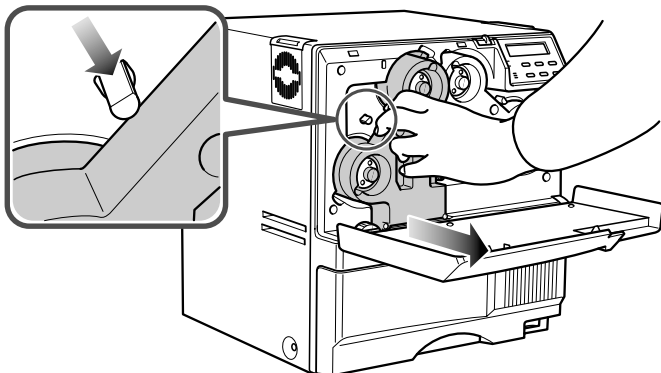

### 3. Insert the retransfer film into the cassette.

Stretch the retransfer film along three shafts with the retransfer face of the film facing outside and insert the bobbins into the bobbin holders firmly. At this time, perform setting so that the film is inside the guide. Wind the film to the wind spool more than three stripes (two frames). Otherwise the printer may fail.

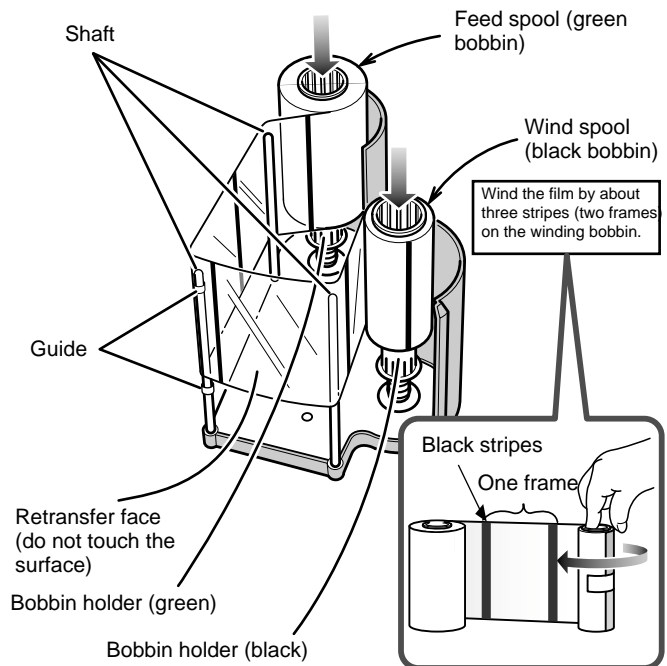

Place the cassette upright on a flat surface during set-up.



### CAUTION

When you need to take out the cassette, for instance, to clean the printer, be sure to put it upright as shown in the above illustration. When the film is put on the table with its retransfer face down, dusts attach to the surface, causing a failure of the printer.

#### 4. Wind the retransfer film to take up the slack.

Turn the knob in the arrow direction to wind a small portion of the retransfer film. If the film does not wind up, go back to step 3, and insert the bobbins firmly into the bobbin holders.

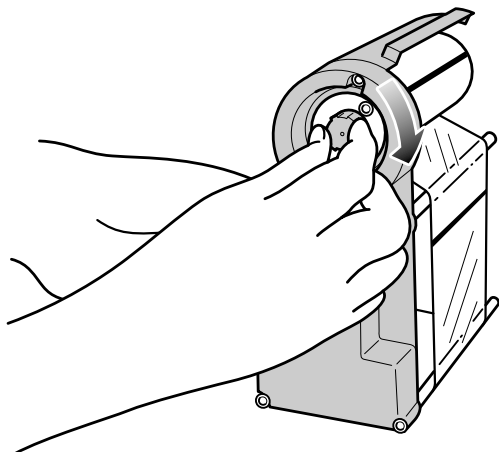

#### CAUTION

If the film is not tightly wound, the slack may cause the film to be caught in the parts of the printer when you set the cassette, or damaged due to wrinkles on the film. At this time, do not hold the film to remove slack. Winding deviation causes operation errors or defective prints.

#### 5. Open the printer door and insert the cassette.

Insert the cassette until it clicks securely into position. The lever returns to its original position.

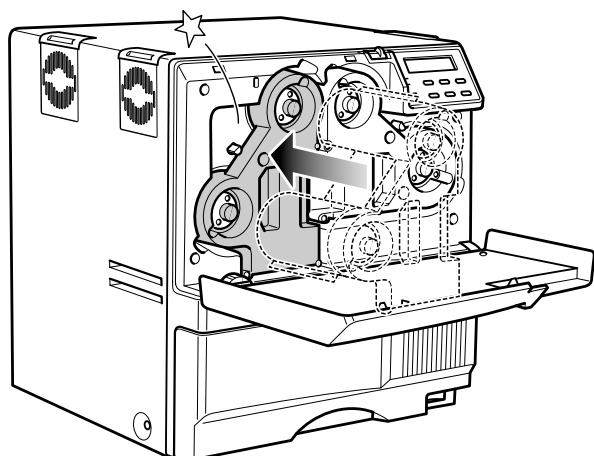

#### CAUTION

The cassette containing the retransfer film is heavy. Hold the cassette with both hands when you set or take out the cassette.

#### 6. Setting the number of frames to be used.

The number of frames of the retransfer film being used is set.

For details, refer to the "Media Type" setting on page 33.

This work must be done when the used film (number of frames) is changed.



#### CAUTION

When the setting of number of frames is not correct, the printed picture may be entirely shifted on the card.

#### 7. Close the printer door.



#### Memo

When the retransfer film is wound up to the end,

**Media Run Out**

appears on the LCD panel.

After replacement press the RESET button, then press the ENTER button.

If the retransfer film is not set properly,

**Media Search**

or

**Media Broken**

appears on the LCD panel. When these messages are output, check:

- The retransfer film is firmly inserted into the bobbin holders.
- The retransfer face of the film is directed correctly.
- The feeding and winding bobbins are mounted correctly.



#### Memo

To mount the retransfer film which is partially used, set the unused portion of the film on the bobbin holder indicated with an arrow on the seal of the cassette.

Printing with the transfer film set improperly may cause the image to be faint.

## Set-up (continued)

### Caution when loading the retransfer film cassette and/or the ink ribbon cassette

The following caution shall be kept when the retransfer film cassette and/or the ink ribbon cassette is removed because of card jam or other trouble.

Please pay enough attention so that the retransfer film and/or ink ribbon is maintained at the right position. Particularly, the ink ribbon is extremely thin, therefore it apt to slip down when the cassette is removed as shown in the illustration.

#### Improper Winding

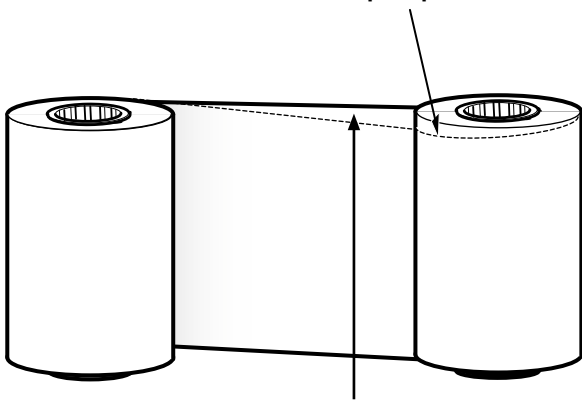

Adjust the position with hands so that the media position of take-up side and supply side becomes parallel

When loaded in this condition, it may cause improper printing such as INK RUNOUT error, improper color printing etc.

To avoid this, please handle the ink ribbon and/or the retransfer film very carefully with hands so that the media position of take-up side become parallel.

Please do not touch the print side of the ink ribbon and/or the retransfer film with your hands. Otherwise, it may cause improper printing.

When adjusting the print position of the retransfer film and/or ink ribbon, please follow the instruction label attached on the cassettes.

### Setting cards

Please use cards specified by your dealer. This unit can take both 0.76 mm(0.03inches)-thick and 0.25 mm (0.01inches)-thick cards. The factory setting is for 0.76 mm-thickness.



#### CAUTION

Fingerprints, soiling, etc. on card surface can result in print errors. Wear lint-free gloves when handling.

#### Inserting cards

The unit can take about 300 0.76mm-thick cards. As for 0.25mm thick cards do not insert more than 300 pieces.

(This 300 pieces is not a guaranteed quantity. In the event of card feed failure, caused by card bending or others reduce card quantity.)



#### CAUTION

When removing new cards from the box, it is possible that cards may be stuck due to static electricity. In this case, peel the cards off one at a time before setting into position. Hold the edges of the card when carrying out these operations.

#### 1. Open the card tray.

Hold the lower part of the card tray and pull the tray toward you slowly until it no longer moves.

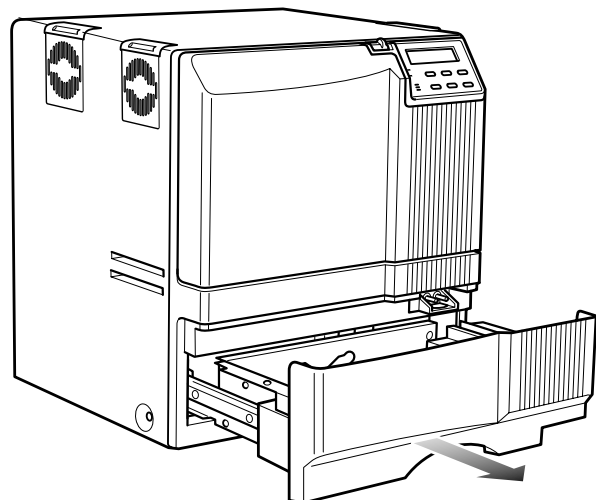

2. Pull the card bracket back.  
The card bracket locks when it reaches the hole.

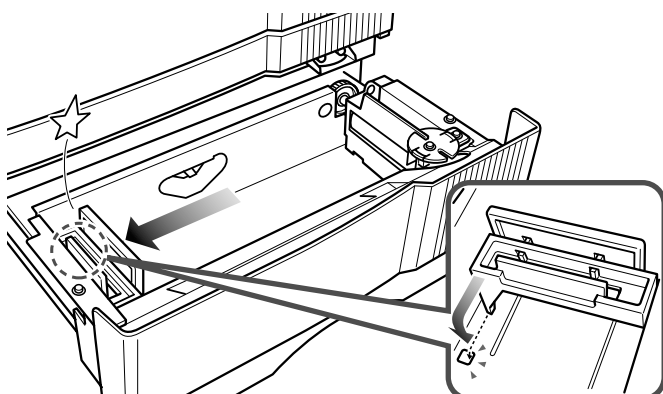

3. Insert the cards and move the bracket back into position.

Limit the number of cards as the card bracket moves back slightly from the lock position.



**CAUTION**

Setting the cards improperly can cause feed jams. Check that the cards are neatly arranged.

Align the cards neatly with the side

Be sure that the tops of the cards are aligned properly

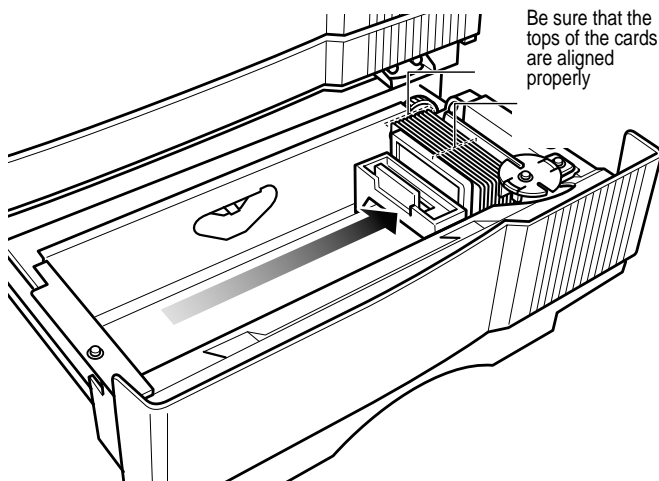

**CAUTION**

When moving the card bracket back into position, do this slowly to avoid jamming your fingers. Leaving the card bracket out of position may cause card jams.

4. Close the card tray.

Push the card tray back into the printer until it no longer moves.

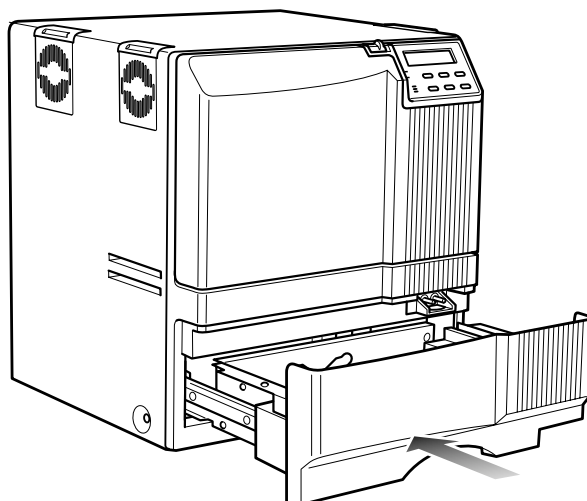

**CAUTION**

To print pre-printed cards on this printer, determine print layout, color tone and card inserting direction by in advance consulting your dealer. Especially for card pre-printed in a dark color such as black, card positioning error may happen. And for a magnetic or IC card, encoding error may happen.



**CAUTION**

When handling cards, avoid dusty environment and use the attached gloves. Dusty cards such as those finger marked may cause improper printing. Consult your dealer to purchase new gloves.

# Set-up (continued)

## When using magnetic cards

When using cards with magnetic strips, set the cards in the following manner.

For JIS II cards:

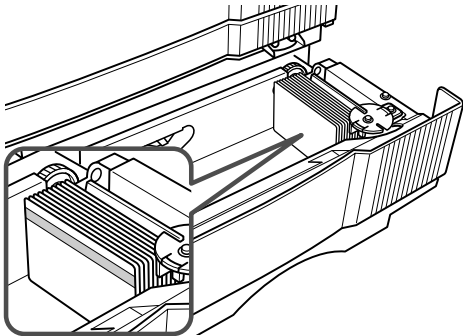

Place the card with its magnetic stripes upward and facing the card bracket.

For ISO cards:

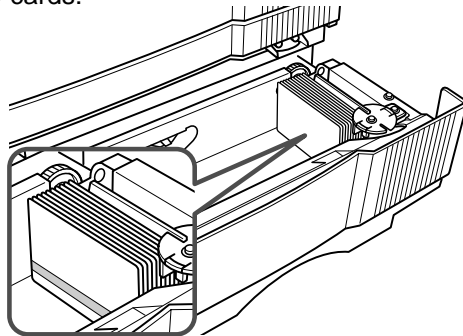

Place the card with its magnetic stripes downward and facing the card bracket.

 **CAUTION** Printing on cards with magnetic strips is not guaranteed.

## When using contact IC cards

When using contact IC cards, set in the following manner.

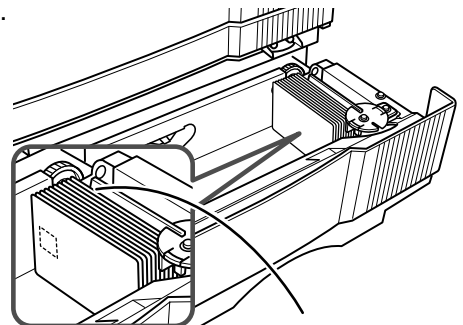

Place the IC card with its IC terminal inward and facing the card bracket.

## Loading cards

Load cards when the printer's LCD panel shows the message "Ready" or "No Card", and not when printer operations have stopped due to an error. Cards can also be loaded when the power supply is not switched on. If there is a drop in the volume of remaining cards (under about 25 cards with a thickness of 0.76mm), the electronic beep sounds before every feeding. (See p.34 in this manual.)

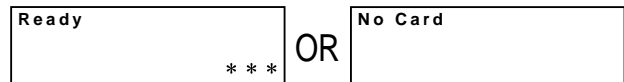

**Loading**

When "Loading" is displayed on the LCD panel, do not open the card tray under any circumstances. The unit is currently feeding cards. If a message other than the one above is displayed, cards can be loaded even while the unit is printing. However, you are recommended to load cards when the unit is not printing.

To prevent defective printing caused by suspended printing or vibration as a result of opening and closing the card tray, load cards with care.

## Switching the card thickness

Depending on the material, some 0.25mm(0.01inches) thick cards may not be suitable for printing. Consult your dealer regarding the materials and specifications of the card before purchasing.

### **WARNING**

- As for switching the card thickness, consult your dealer or the service personnel. Otherwise injuries or malfunction of the printer may be caused



Electric shock



Injury

## Connecting with a host computer



### CAUTION

● Do not switch off the power of the host computer during printing.

● Do not use the sleep or the stand-by function on the host computer.

If the power of the host computer is switched off during printing, or if the sleep or the stand-by function of the host computer is activated, the printer may stop with cards printed halfway remain in the printer. When this occurs, initialize the printer as "Stopping when printing" of page 48 on this manual.



### CAUTION

● The location of terminals varies with the host computer. Please refer to the instruction manual of the host computer.

● When there are multiple USB cable connection terminal on the host computer, either one can be used.

● Do not connect to the USB connection terminal on the host computer's monitor or keyboard. It may not be recognized correctly.

● When using a USB hub, connect to the hub that is directly linked to the host computer.

## Connecting with USB cable

1. Check to ensure that the power of both the printer and host computer are switched off.
2. Connect the printer and host computer with the USB cable.  
Insert the USB cable to the USB cable connection terminal at the back of the printer.

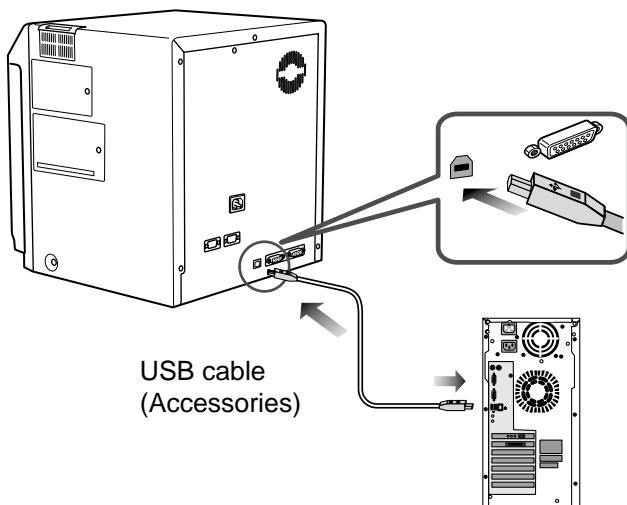

### CAUTION

Adjust orientation of the USB cable according to the terminal, and insert it all the way in.



### CAUTION

Consult your dealer on the cable connection if there are USB or serial cable connection terminal on the printer's optional port.

## Connecting with Ethernet cable

1. Check to ensure that the power of both the printer and host computer are switched off.
2. Connect the printer and network HUB is connecting the host computer with the Ethernet cable.  
Insert the Ethernet cable to the Ethernet cable connection terminal at the back of the printer.

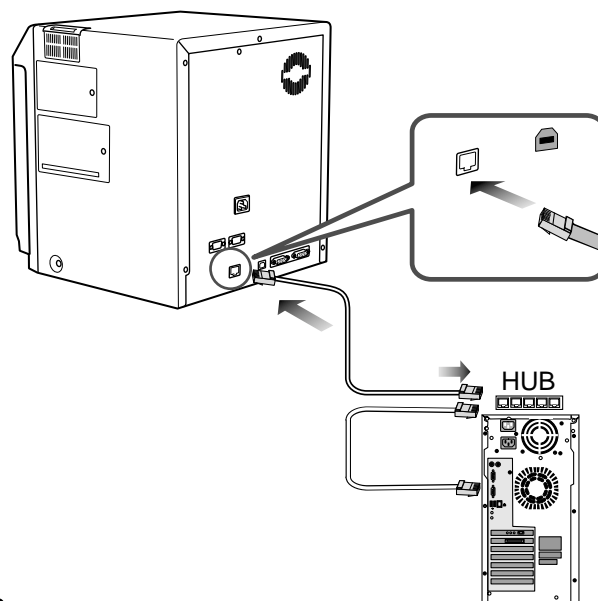

### CAUTION

USB has priority if an USB cable is connected during power on.



### CAUTION

Insert the LAN cable all the way in until it stops according to the orientation of the terminal.



### CAUTION

To avoid any malfunctions, use a sealed type LAN cable.

### Connecting Multiple Printers

When connecting a host computer to multiple printers, set different Unit Numbers from 1 to 7 for each printer. Refer to see the page 36 of the instruction manual.

To connect multiple printers to a network, you must configure the IP addresses for a every printer, For details, see page 37 of this documentation.

### The Copyright of the Software is displayed

This product includes software developed by the Open SSL Project for use in the Open SSL Toolkit.(<http://www.openssl.org/>)

This product includes cryptographic software written by Eric Young([ey@cryptsoft.com](mailto:ey@cryptsoft.com)).

This product includes software written by Tim Hudson([tjh@cryptsoft.com](mailto:tjh@cryptsoft.com)).

## Names of parts on the operation panel

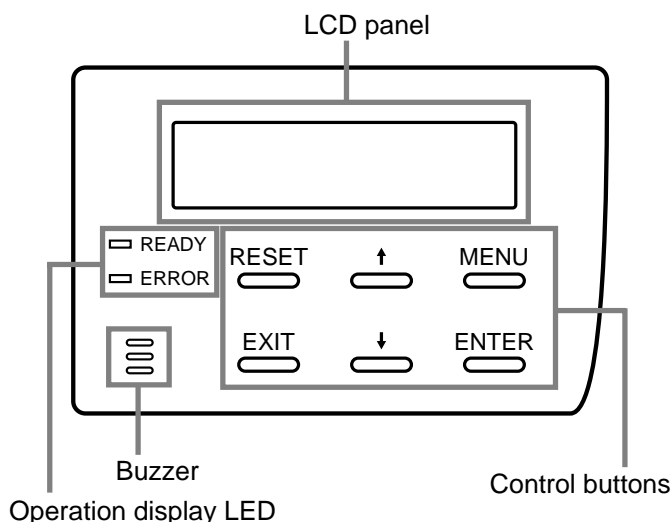

### Setting buttons

**RESET**  

Initializes the printer by the software when an error occurs or an error is cancelled.

**MENU**  

The user mode setting is displayed when the unit is in the Ready or Preheating status. The button is also used when canceling the operation lock during errors.

**ENTER**  

Confirms the mode selected in the user mode setting.



The parameter setting for each mode can be adjusted during the user mode setting. Make sure to press the button to save the settings.

**EXIT**  

Quits setting and returns to the upper level setting screen.

### Operation display LED

#### READY LED (green)

- ON : unit ready, printer in operation
- Flashing : receiving image data
- OFF : unit stopped due to error, or unit being set, initialized or preheated.

#### ERROR LED (red)

- ON : operation error
- OFF : normal status

If an error occurs while the buzzer is set to ON, an alarm will sound. If this happens, the LCD background color will change to red.

### LCD panel

#### During normal operation

- Upper line : operation status display  
(For details concerning the operation display, see p. 24 of this manual.)
- Lower line : counter display  
(Toggles between total counter/head counter/ free counter and roller counter.)

#### If an error occurs

- Displays the error status.  
(For details concerning the error display, see p. 46 - 47 of this manual.)

#### During user mode

- Displays various setting modes.  
(For details concerning settings, see p. 28 in this manual.)

#### Display background color

- Bright green : OS booting up
- Orange : Card feeding
- Red : Error

The above background colors can be selected in user mode settings.  
(For details concerning settings, see p. 30 in this manual.)

# Before use (continued)

## Operation display LED contents and the LCD panel

Printer status	READY	ERROR	LCD panel
Mechanism set period			Initializing..
Preheat period			Preheating..
Ready period			Ready
Printer operation period			When an error occurs
Error occur			*Depends on the error content
User mode			Depends on the user mode content

: LED on  
 : LED off

For details, see p. 46 – 47 of this manual.

### Initialization period

When the power is turned on, the printer performs positioning of the ink ribbon and retransfer film. It also initializes the mechanisms of the printer and check their operations. "Initializing" is displayed on the LCD panel during this period.

### Preheating period

When the initialization of the mechanisms completes normally, the printer increases the temperature of the retransfer roller and bend remedial roller up to the specified levels. "Preheating" is displayed on the LCD panel during this period.

## LCD operation display content

<b>Boot Up..</b> xxxxxxx	OS booting up
<b>Ver. xxx/xx/xx</b> <b>INT Complete</b>	* Firmware version Shows firmware version number.
<b>Initializing..</b> xxxxx * * *	Displayed during the initialization process.

<b>Preheating..</b> xxxxx * * *	Displayed during preheating * Displays Total/Head/Free or Roller(Display is Roll.), according to the counter select setting.
<b>USB Ready</b> xxxxx * * *	Ready status (USB connection) * Print counter
<b>NET Ready</b> * * * * * * * * * * * *	Ready status (LAN connection) Network address
<b>Getting IP</b>	Getting IP address (In case of DHCP ON)
<b>Loading..</b> xxxxx * * *	Displayed during feeding
<b>Printing..</b> xxxxx * * *	Displayed during printing
<b>Encoding..</b> xxxxx * * *	Displayed during encoding
<b>Heating..</b> xxxxx * * *	Displayed during adjusting the temperature for setting value
<b>Retransfer..</b> xxxxx * * *	Displayed during retransfer
<b>Unloading..</b> xxxxx * * *	Displayed when cards are discharged from the NG card outlet
<b>Cleaning..</b>	Displayed during cleaning operations
<b>Sleeping..</b>	When the heater status is OFF because of the power save function

### Memo

When the heat roller temperature setting has been changed or after setting the Low temperature stand-by mode, HEATING will be displayed if the configured temperature does not match the actual temperature before the retransfer operation starts.

## Turning on the power

1. Before turning on the power, check the following:  
Make sure that the printer door is completely closed.  
Make sure that the card tray is completely closed.  
Make sure that the host computer is correctly connected.  
Make sure that any peripheral equipment is correctly connected.  
Make sure that the power supply outlet is correctly connected.  
(Power on the laminator first, if connected.)  
Only switch the unit on after checking the above points.

2. Turn the power ON.

(I represents ON and O represents OFF.)

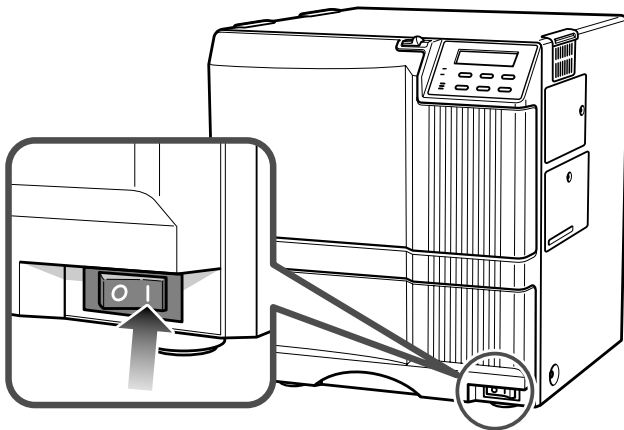

3. The unit will be in the ready status approximately 4 minutes after turning on the power.

The operation display LED (READY LED) will light up.

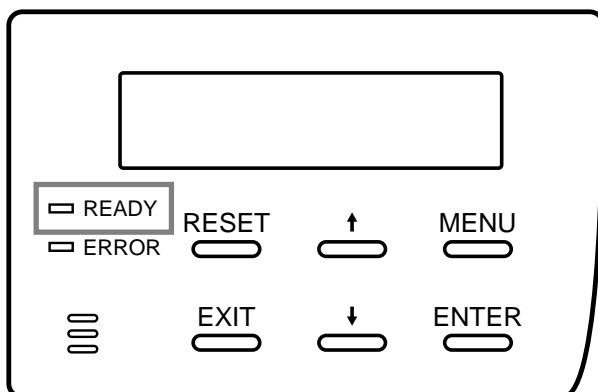

### CAUTION

Do not turn the power off while the LCD panel displays 'Boot up' to 'Initializing', as this may cause malfunctions.

### Making settings in the user modes

When the LCD panel displays Ready or Preheating,

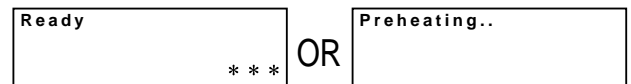

press  button.

For details concerning each user mode setting, see p. 28 of this manual.

4. Enter the control command from the host computer to print cards.

The operation display LED (READY LED) will flash while the unit is receiving image data from the host computer.

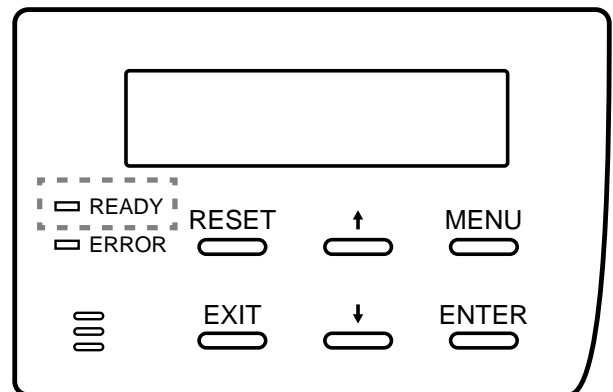

Be sure NOT to do any of the following during printing operations and initialization process :

- Do not open the printer door.
- Do not open the card tray.  
(while the LCD panel displays 'Loading')
- Do not turn off the power supply.
- Do not unplug the unit.
- Do not pull out the connection cable.

Failure to observe the above points will cause printing to be aborted and may result in a malfunction of the unit.



## CAUTION

When the printer was occurred an error during printing operation caused by above-mentioned operation or others, the retransfer film was rewinded about 3 panels. If the printer is turned off and on the power or is initialized, the printer occur the printing an error which is "INK RUNOUT" or print results problem because of the printer try to print the used retransfer film. Wind up the retransfer film about 3 panels by unused panel. See p.18 "Caution when loading the retransfer film cassette and/or the ink ribbon cassette" and p.26 "On initialization when the retransfer film cassette and/or the ink ribbon cassette is loaded".

## Turning off the power

1. Check the printer status.



In ready, preheat or error status, check that printer operations are suspended.

2. Turn off the power.

Always wait 10 seconds or more before turning the power back on again.



Turn off the power switch when you won't use the printer for a prolonged period of time for power saving.

## About the RESET button

When an error occurs in the printer, press the  button, then the  button.

The printer is initialized with this operation.

If the error still persists, see p.46-47 and take the appropriate actions.

Then, press the  button, and the  button again. The printer is initialized, and returns to the "Ready" state.

(When you turn off the power, these procedures are not necessary.)

## On Initialization when the retransfer film cassette and/or the ink ribbon cassette is loaded

Dust or foreign particles may attach on the surface of retransfer film and ink ribbon when their cassette are removed from the printer.

This may cause defective printing such as image void, defective retransfer etc.



To Avoid this, it is recommended that the retransfer film and the ink ribbon are wound up one or two panels after they are reloaded.

Please follow the initialization procedure described below:

1. Turn the power switch on, and wait until the LCD panel displays "Preheat" or "Ready".

2. Depress the  key.  
LCD panel displays:

Initialize  
OK?

3. By depressing the  key or the  key, the LCD panel change accordingly as shown below. Select the wind-up condition, one or two panels. (This set up is not memorized.)

Initialize  
2'nd Panel, OK?

- Initialized after two panels of the retransfer film and the ink ribbon are would up.

Initialize  
NEXT Panel, OK?

- Initialized after one panels of the retransfer film and the ink ribbon are would up.

Initialize  
OK?

- Initialized without winding up. (Default)

4. By depressing the  key, the printer is initialized according to the selected above set up condition.

## User modes

The settings for printing media, card, etc. can be made in the User mode.

### MENU



Press the MENU button when the unit is in the Ready, Preheat or Error status to suspend printing operations.

## User mode screen flow



### CAUTION

When you change settings for the underlined submenu on the next page, (Setting the retransfer film, Setting the retransfer roller temperature and Bend remedy roller temperature setting), the message "Please Reset" will appear on the LCD panel. Then initialize the printer by pressing

RESET key and next ENTER key.



Press and

User Mode





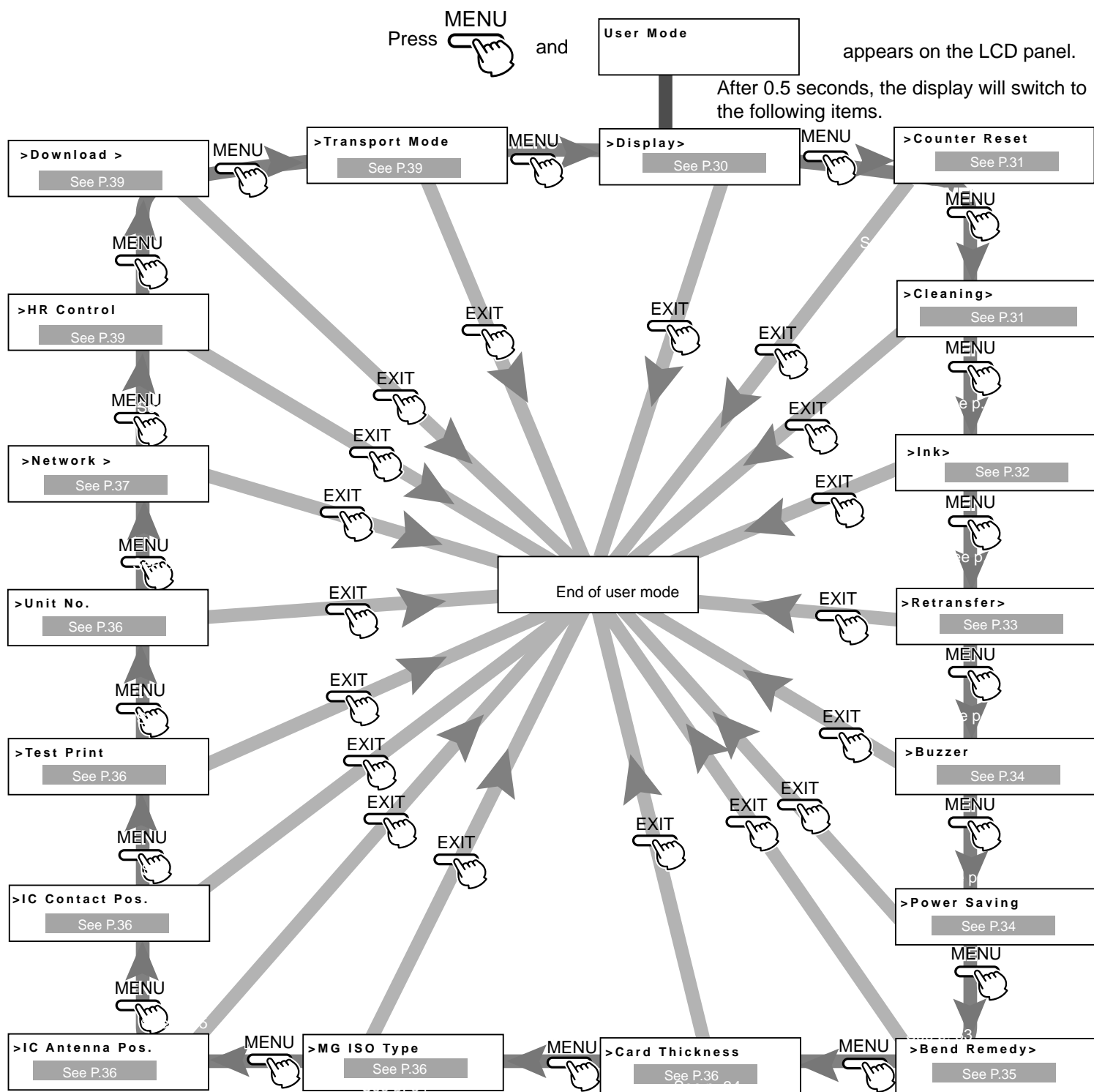







appears on the LCD panel.



After 0.5 seconds, the display will switch to the following items.



# Operation (continued)

## User mode settings

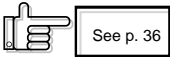
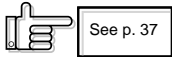
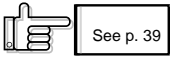
Main menu	Submenu	Factory setting
>Display>  Display mode  See p. 30	>>Counter Total 4 counter type settings: [Total, Head, Free, Rollers]	Total
	>>Contrast 0(Standard) LCD panel contrast setting: 7 gradations from -3 to +3, the higher the value the stronger the contrast.	0
	>>Back Color PURPLE LCD panel background color setting: 8 options	PURPLE
>Counter Reset OK?	Counter reset mode For free counter resetting: press the ENTER button.  See p. 31	—
>Cleaning>	Cleaning mode For cleaning mode setting: Magnetic head and card feeder roller execution  See p. 31	—
>Ink>  Ink mode  See p.32	>>Ink Type YMCK:0 Display on ink ribbon : the ink type being used is displayed Display only because of automatic setting by RF-ID(Setting is not possible)	—
	>>Black Level 0(Standard) Setting the black level K: 9 gradations can be set from -3 to +5, the larger the value the darker the printing.	0
	>>Black Mode Standard Setting the K printing mode: 2 options [standard and fine]	Standard
	>>UV MAC Adr Pos Upper Right Setting of MAC address position in the case of UV print [Upper Right, Lower Left]	Upper Right
	>>UV Level +3(Thick) UV ink level setting: 9 levels of density setting -3 to +5, the larger the value the darker the printing.	+3
	>>SP-Ink2 Level 0(Standard) Setting the special ink SP-Ink2 level: 9 gradations can be set from -3 to +5, the larger the value the darker the printing.	0
>Retransfer>  Retransfer mode  See p. 33	>>Media Type Std(1000/roll):0 Setting the retransfer film: <u>setting the film type</u> [1000,750] - two types	Standard (1000/roll):0
	>>Temp. Level 0(Standard) <u>Setting the retransfer roller temperature:</u> 6 gradations can be set from -3 to +2, the larger the value the higher the temperature.	+1
	>>Speed (Front) +2(Fast) Setting the retransfer speed: 13 gradations can be set from -10 to +2, the larger the value the faster the speed.	+2
	>>Speed (Back) +2(Fast) Setting the rear retransfer speed: 13 gradations can be set from -10 to +2, the larger the value the faster the speed.	+2
	>>MG Print(JIS) Off Setting the way of peeling off the retransfer film: 2 settings [On and Off]	Off
	>>Standby mode Front Wait Laminate Standby selection: In case of both side printing with optional unit connected, select either one of the card sides for standby.2 Settings [Front Wait, Back Wait]	Front Wait
>Buzzer On	Buzzer mode Setting the buzzer ON/OFF: 2 settings [on and off]  See p. 34	On
>Power Saving On	Power saving mode Setting the time for the power saving mode:9 options [off, 5, 10, 15, 20, 25, 30, 45 and 60] (units: minutes)  See p. 34	On
>Bend Remedy>  Bend Remedy mode  See p. 35	>>Temp. Level Off Bend remedy roller temperature setting: 7 gradations can be set from -5 to 0 or off, the larger the value the higher the temperature.	Off
	>>Speed +2 Bend remedy speed setting: 5 gradations can be set from -2 to +2, the larger the value the faster the speed.	+2
	>>Cooling Time None Cooling time setting: 16 gradations can be set: none and 1-15 (units seconds).	None
>Card Thickness Standard	Card thickness setting mode: Card thickness setting: 2 options [Standard, Thin]  See p. 36	Standard
>MG ISO Type Hi-Co	Coercivity setting mode: ISO card coercivity setting: 2 options [Lo-Co and Ho-Co]  See p. 36	Hi-Co
>IC Antenna Pos. None	Non-contact IC antenna setting mode: Non-contact IC antenna position setting: 3 options [None, Ext. Unit, Added on]  See p. 36	—
>IC Contact Pos. None	IC contact position setting mode: IC contact position setting: 3 options [None, Built-in, Ext. Unit]  See p. 36	—
>Test Print OK?	Test print mode: to carry out test printing: press the ENTER button.  See p. 36	—

Main menu	Submenu	Factory setting
<div style="border: 1px solid black; padding: 2px;">&gt;Unit No. No.1</div>	Unit No: 7 options [No.1 to No.7] Unit No. setting: press the ENTER button. 	No.1
<div style="border: 1px solid black; padding: 2px;">&gt;Network&gt;</div> <p>Network mode The current IP address is displayed</p> 	<div style="border: 1px solid black; padding: 2px;">&gt;&gt;Printer Name PRINTER01</div> Printer name entry, Please select the PRINTER 01-09 and another name is enter from the host computer (within 10 letters or numbers)	PRINTER01
	<div style="border: 1px solid black; padding: 2px;">&gt;&gt;Host Interface LAN</div> Select Interface [USB, LAN ]	LAN
	<div style="border: 1px solid black; padding: 2px;">&gt;&gt;DHCP On</div> Availability of DHCP. [On, Off ]	On
	<div style="border: 1px solid black; padding: 2px;">&gt;&gt;IP Address 192.168.0.141</div> IP address settings (Setting when DHCP is Off)	192.168.0.141
	<div style="border: 1px solid black; padding: 2px;">&gt;&gt;Subnet Mask 255.255.255.0</div> Subnet Mask settings (Setting when DHCP is Off)	255.255.255.0
	<div style="border: 1px solid black; padding: 2px;">&gt;&gt;Gateway 192.168.0.1</div> Default Gateway settings (Setting when DHCP is Off)	192.168.0.1
	<div style="border: 1px solid black; padding: 2px;">&gt;&gt;Session TimeOut Off</div> Net Session Timeout Settings [Off, 10min, 20min, 30min, 60min]	Off
	<div style="border: 1px solid black; padding: 2px;">&gt;&gt;MAC address 0080-8842-8B00</div> Displayed of MAC address	
	<div style="border: 1px solid black; padding: 2px;">&gt;&gt;IPSec Mode off</div> Availability of IP Sec.[Off , On ] (When IP Sec Type is "not setting", it is fixed at Off)	Off
	<div style="border: 1px solid black; padding: 2px;">&gt;&gt;IPSec Type not setting</div> Display of IP Sec authentication method not setting, Preshared (presharing of key authentication), Certificate (Public key certificate)	not Setting
<div style="border: 1px solid black; padding: 2px;">&gt;HR Control off</div>	Low Temperature Standby mode setting [On, Off ] 	Off
<div style="border: 1px solid black; padding: 2px;">&gt;Download&gt; OK?</div>	Firmware Download mode Press the ENTER button to enter download mode.. 	_____
<div style="border: 1px solid black; padding: 2px;">&gt;Transport mode OK?</div>	Transport Mode: Transport mode setting: press the ENTER button. 	_____

## Display mode settings

The unit has the following three settings for the display mode. Allows selection of which counter value is displayed when the power is turned on.



### CAUTION

- The beep sounds when pressing the Enter button to save the settings in the user setting mode.
- The beep will not sound if the buzzer mode setting (see p.34) is set to off.

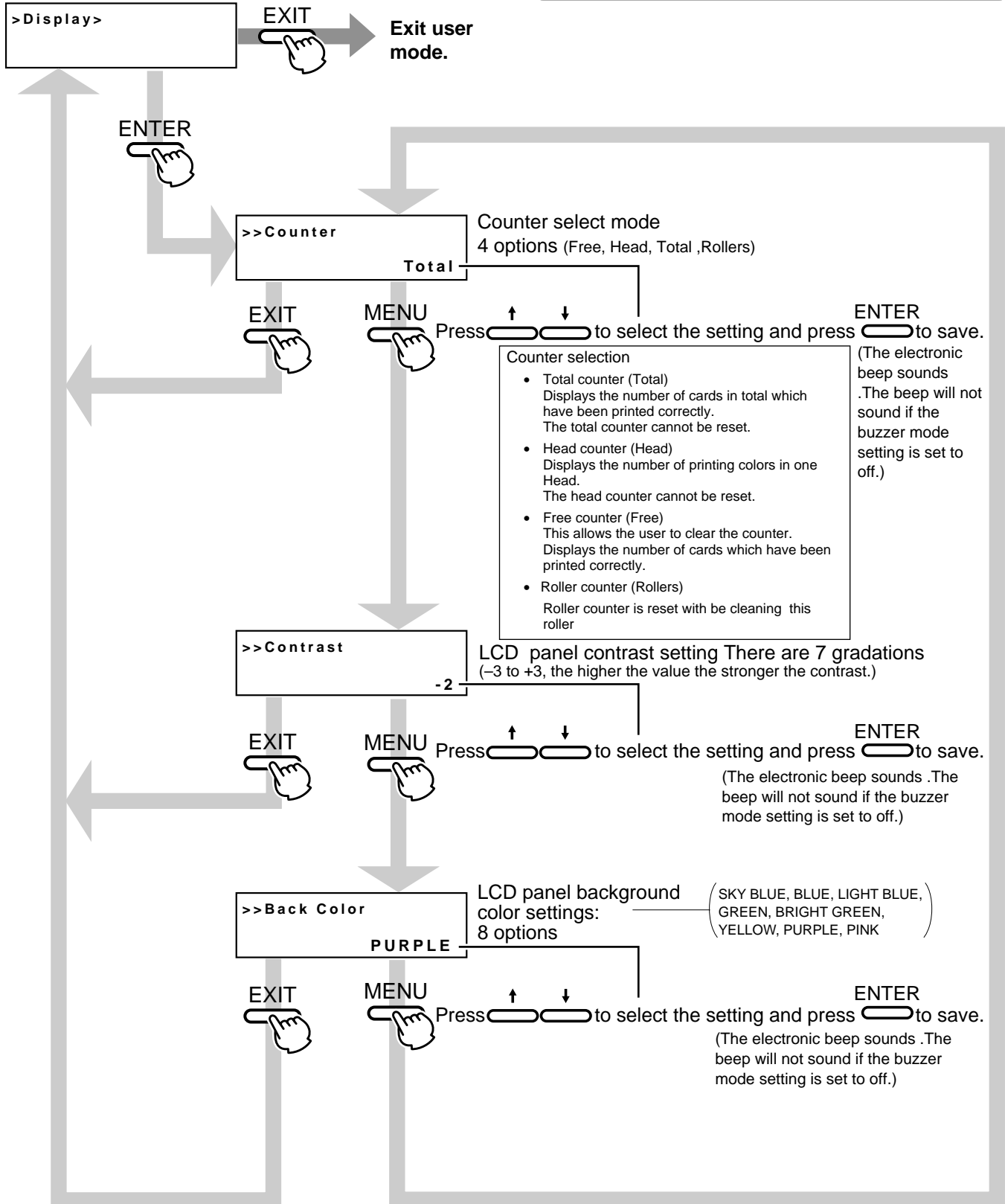

## Clearing the free counter

Reset the free counter.  
The [Total] counter and [Head] counter cannot be reset.

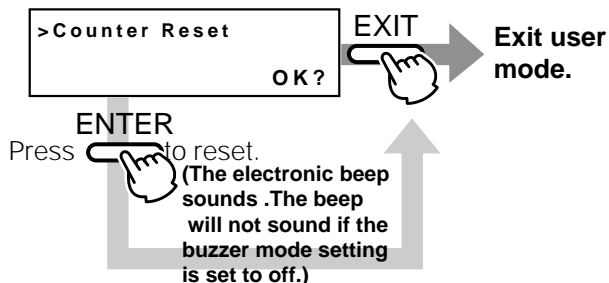

To check that the counter is reset to zero, select "Free Counter" in "Setting the counter type" on p.29.

 **CAUTION** The head counter is cleared to zero each time the thermal head is replaced.

## Cleaning mode

The printer is provided with an operation mode for cleaning the card feed roller and the magnetic head to keep the printer in the best condition.  
See p.42,43 and p.44 for executing the cleaning mode.

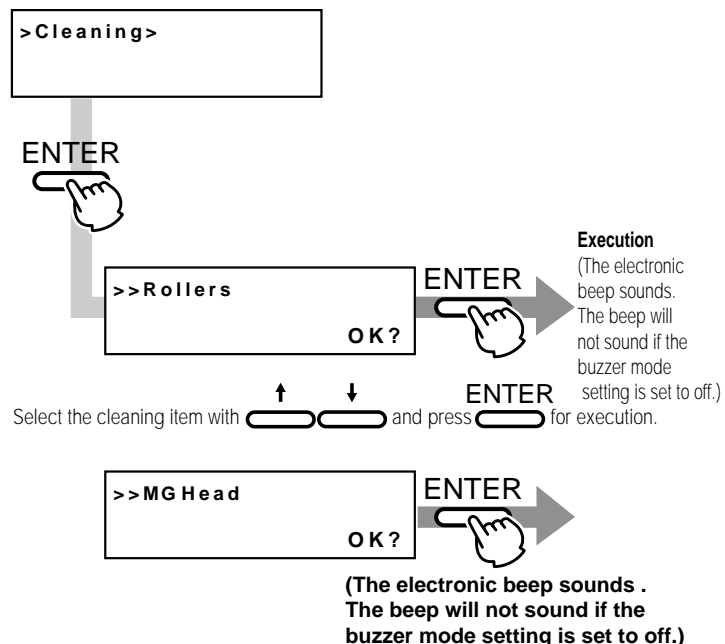

To exit the cleaning mode, turn off the power after cleaning.

## Ink mode setting

Change settings according to the ink ribbon used.

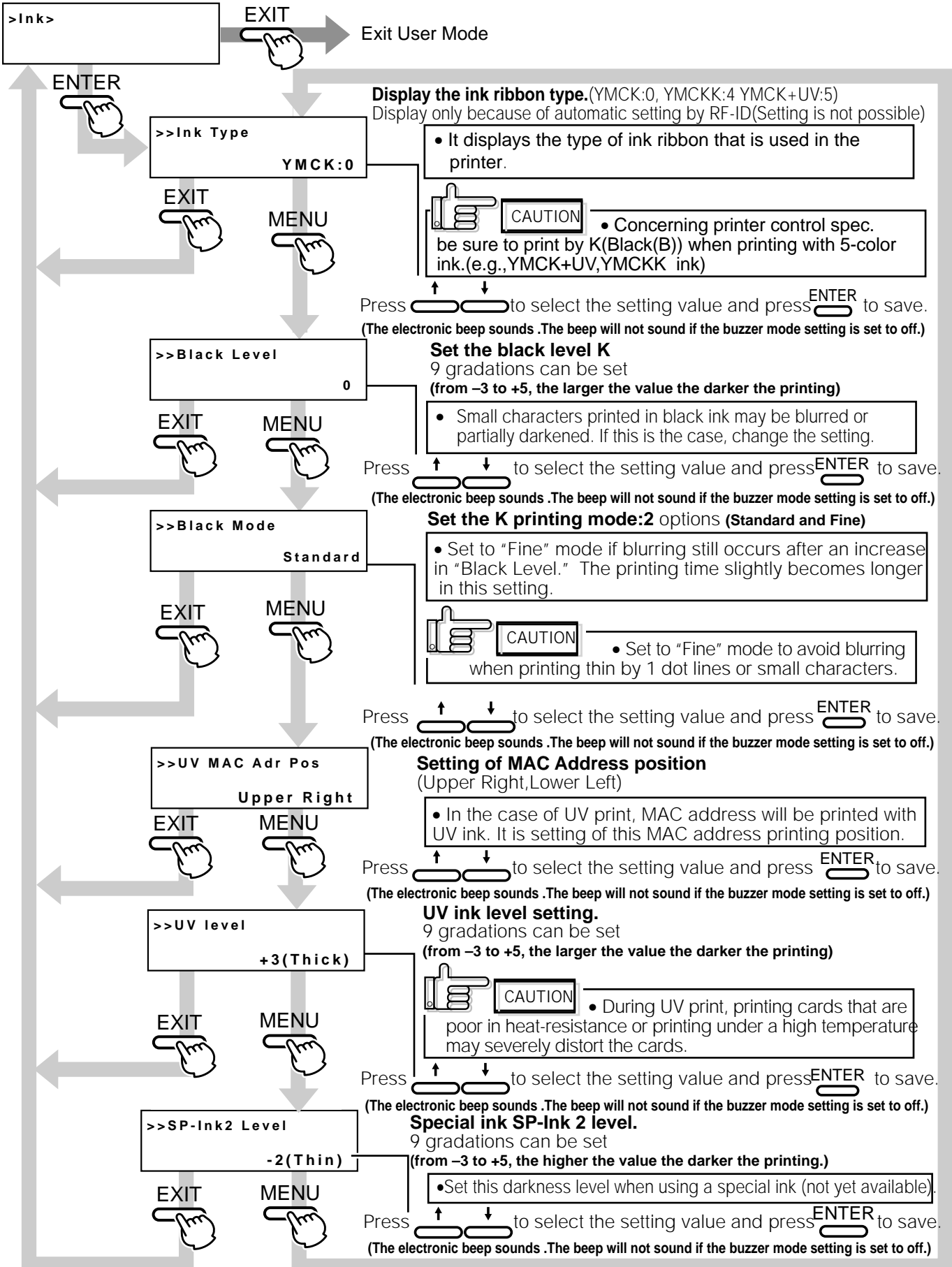

# Retransfer mode setting

Change settings according to the retransfer film and card used.

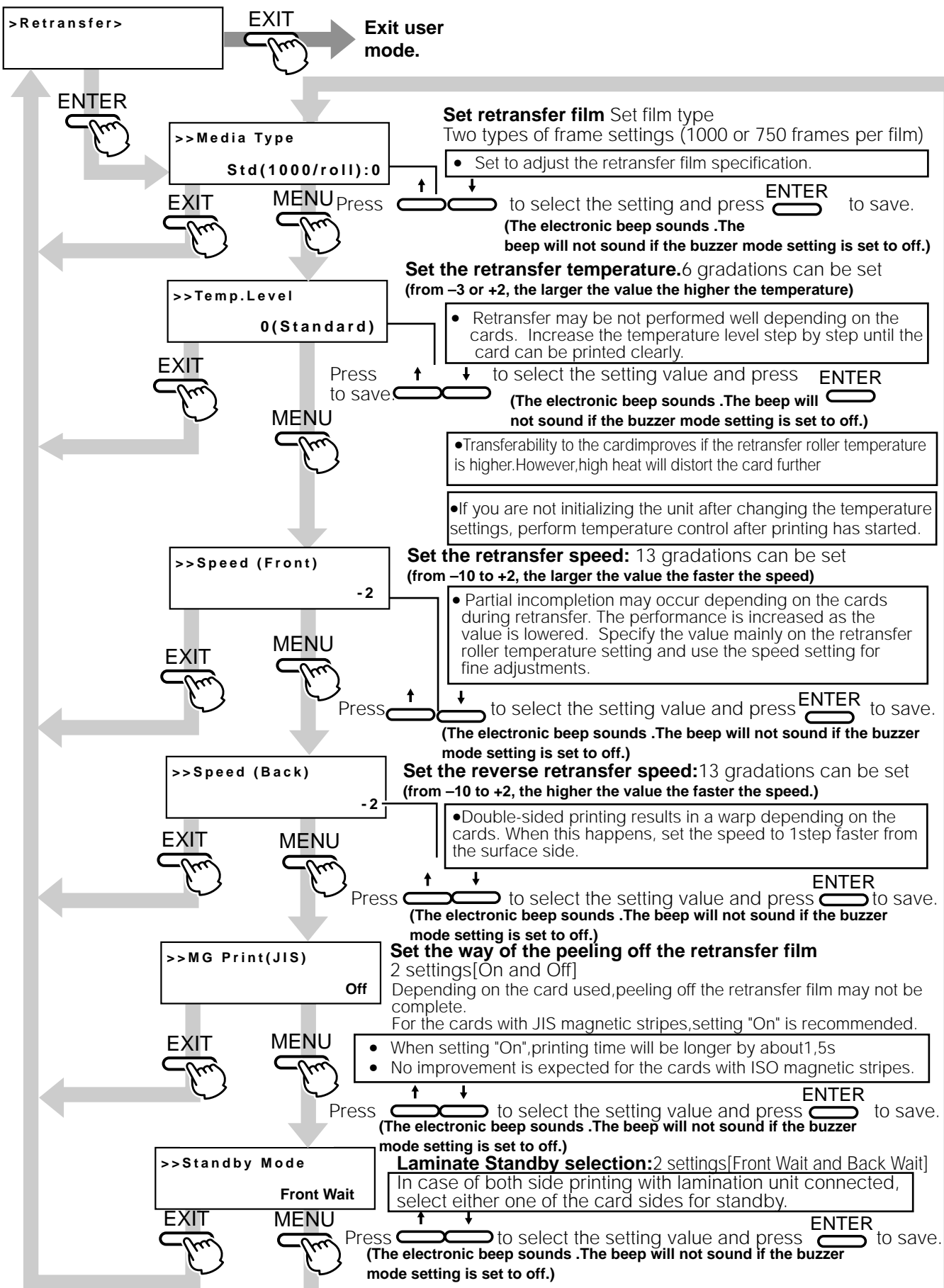

## Buzzer mode setting

The buzzer indicating errors can be turned on or off.

**Set the buzzer:**  
there are two settings  
(On, off)

Press to select the setting and press to save.  
(The electronic beep sounds. The beep will not sound if the buzzer mode setting is set to off.)

When Off is specified,

- electronic beep sound indicating an error,
- electronic beep sound indicating the number of cards, and
- electronic beep sound indicating settings saved with the ENTER button in the user mode are muted.

## Power saving mode settings

The printer enters into the power save mode after a specified period of time if none of operation buttons are touched in the Ready state. The heat roller for retransfer, bend remedial roller, and back-light of the LCD panel are turned off in the power save mode.

**Power saving settings:**  
there are 9 options.

Press to select the setting and press to save.  
(The electronic beep sounds. The beep will not sound if the buzzer mode setting is set to off.)

Press the EXIT button to cancel the user mode, and the printer starts.

Off:

Not in power saving mode.

Setting options: [5,10,15,20,25,30,45,60] (units: minutes)

If printing is not to be carried out for a period longer than the set time, switch the units heater off. (Power save status)

“Sleeping” appears on the LCD panel in the power save mode. The operation buttons are disabled in this mode. See step 2 in “Canceling the power save mode” to enable the operation buttons.

Sleeping

The printer moves to the power save mode when the specified time arrives even if you turns off the printer and turn it on again.

Canceling the power save mode

1. From the host computer

Enter a control command to print the card. The power save mode is cancelled, and printing automatically starts upon completion of preheating.

2. Temporary cancellation

To cancel the power save mode temporarily on the printer, press , then to initialize the printer.

3. Permanent cancellation

Cancel the power save mode temporarily as described in step 2, and change the power save mode setting to OFF.

## Setting the bend remedy mode

Single-sided printing may cause a bend depending on the cards. Adjust the setting to get rid of the bend.

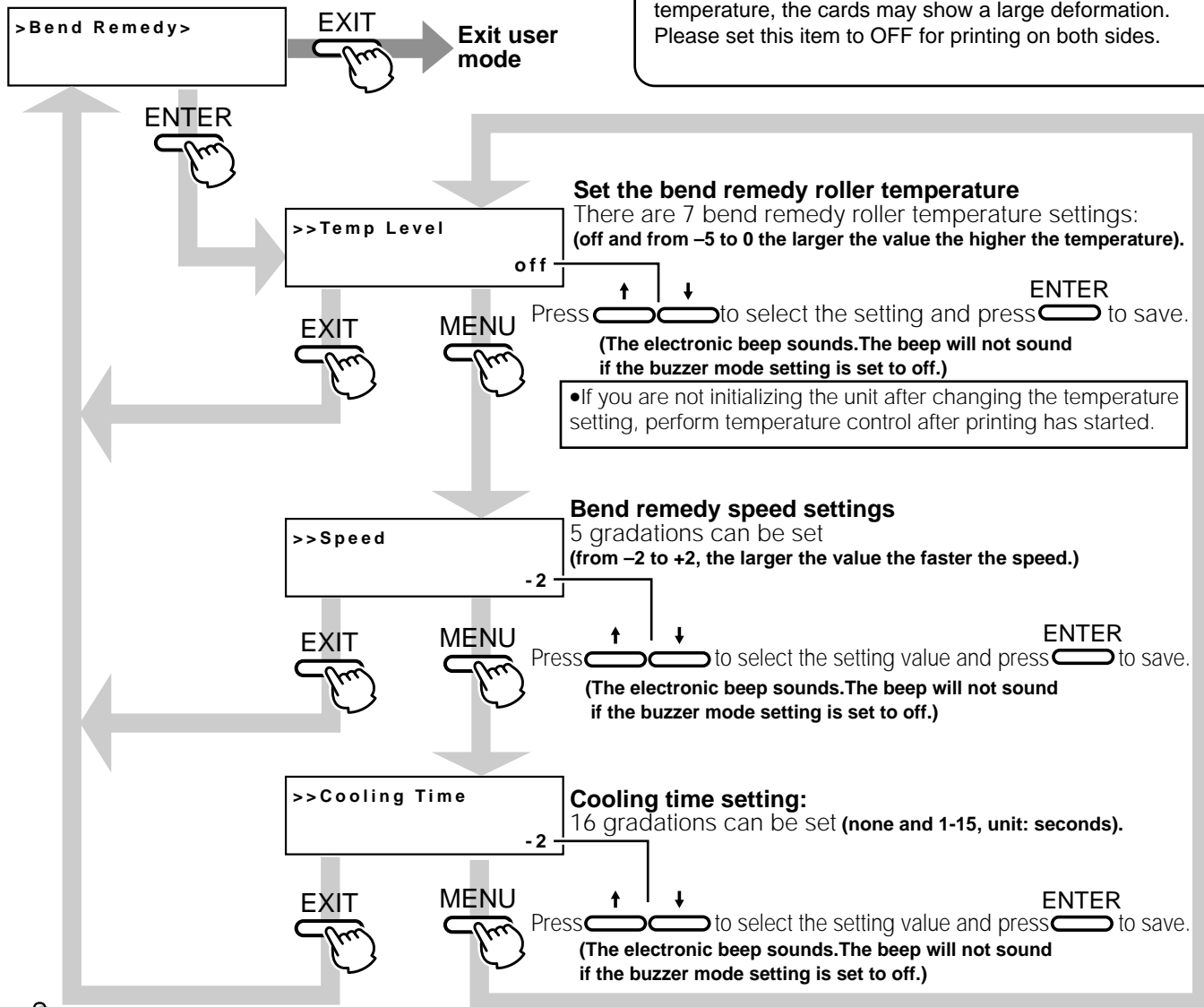

**CAUTION** When printing on both sides is done with "Remedy roller temperature setting" set to a high temperature, the cards may show a large deformation. Please set this item to OFF for printing on both sides.

**CAUTION** If the bend remedy temperature setting is set to off from any other setting, the preheating status will remain the same until the roller temperature falls (for approximately 10 minutes). This is not a malfunction. Leave the unit in ready status and wait.

**CAUTION** When printing on both sides with "Bend remedy roller temperature setting" set to a high temperature, the cards may show a large deformation. Please set this item to OFF for printing on both sides.

**Memo**

1. Setting temperature and speed of the bend remedial roller. Adjust the "roller temperature" setting in principle to correct the bend of the card, and use the "correction speed" setting for fine adjustments.
2. Setting waiting time for cooling the card  
This provides the time for a special film, which will be marketed in the future, to cool down to prevent the card and retransfer film from sticking together after printing.

**CAUTION** When the Bend remedy roller temperature setting is high or when the bend remedy speed is slow, the bend remedy force is stronger but the surface become matte easily. Therefore, set a low temperature as far as possible.

## Card Thickness setting mode

The printer is designed to load only the 0.76mm or 0.25mm thick cards. So set card thickness depending on the card used.

>Card Thickness  
Standard

EXIT → Exit user mode

Set the card thickness:  
2 settings  
[Standard and Thin]

Press to select the setting and press to save.  
(The electronic beep sounds. The beep will not sound if the buzzer mode setting is set to off.)

Standard: 0.76mm (0.03 inches)-thick  
Thin: 0.25mm (0.01 inches)-thick

For changing card thickness, see "switching the card thickness" on Page 21 of this manual

## Coercivity setting mode

Set coercivity for writing data on the ISO compatible magnetic stripe card.

>MG ISO Type  
Lo-Co

EXIT → Exit user mode

Press to select the setting and press to save.  
(The electronic beep sounds. The beep will not sound if the buzzer mode setting is set to off.)

Lo-Co  
238×10<sup>2</sup> [A/m] (300 [Oe])  
Hi-Co  
218×10<sup>3</sup> [A/m] (2750 [Oe])

## Non-contact IC antenna setting mode

To use non-contact IC cards, set the antenna position at which the cards stop.

>IC Antenna Pos.  
None

EXIT → Exit user mode

Non-contact IC antenna position:  
3 settings

Press to select the setting and press to save.  
(The electronic beep sounds. The beep will not sound if the buzzer mode setting is set to off.)

None  
No antenna  
Ext. Unit  
An IC unit antenna is being used  
Added on  
A compact IC unit is being used.

## IC contact setting mode

When using IC cards, specify the contact position to stop the cards.

>IC Contact Pos.  
None

EXIT → Exit user mode

Set IC contact position:  
3 settings

Press to select the setting and press to save.  
(The electronic beep sounds. The beep will not sound if the buzzer mode setting is set to off.)

None  
No contact  
Ext. Unit  
An IC unit contact is being used  
Built-in  
A built-in contact is being used

## Test print

Test print is provided for printing a test pattern contained in the printer (there is only one pattern). Operating the printer independent of the host computer enables you to find out the source of trouble if there is a problem in the system.

>Test Print  
OK?

EXIT → Exit user mode

Press to carry out test printing.  
(The electronic beep sounds. The beep will not sound if the buzzer mode setting is set to off.)

Printing..

A single-sided color pattern is printed. When test printing is completed, the unit will automatically return to ready status.

## Unit No. Setting

Set Unit Number of the printers to be connected

>Unit No.  
No.1

EXIT → Exit user mode

Unit No:  
7 settings

Press to select the setting and press to save.  
(The electronic beep sounds. The beep will not sound if the buzzer mode setting is set to off.)

After that press , Then the message is displayed as shown below.

Please,  
Power Off

Turn off the power  
And then by turning on the power,  
Unit No. setting mode is cancelled.

# NETWORK setting



- Determine the "Network Setting" items according to the instruction of the network administrator for the location where the printer unit is installed.
- Other network devices may be affected if the "Network Setting" is incorrect.

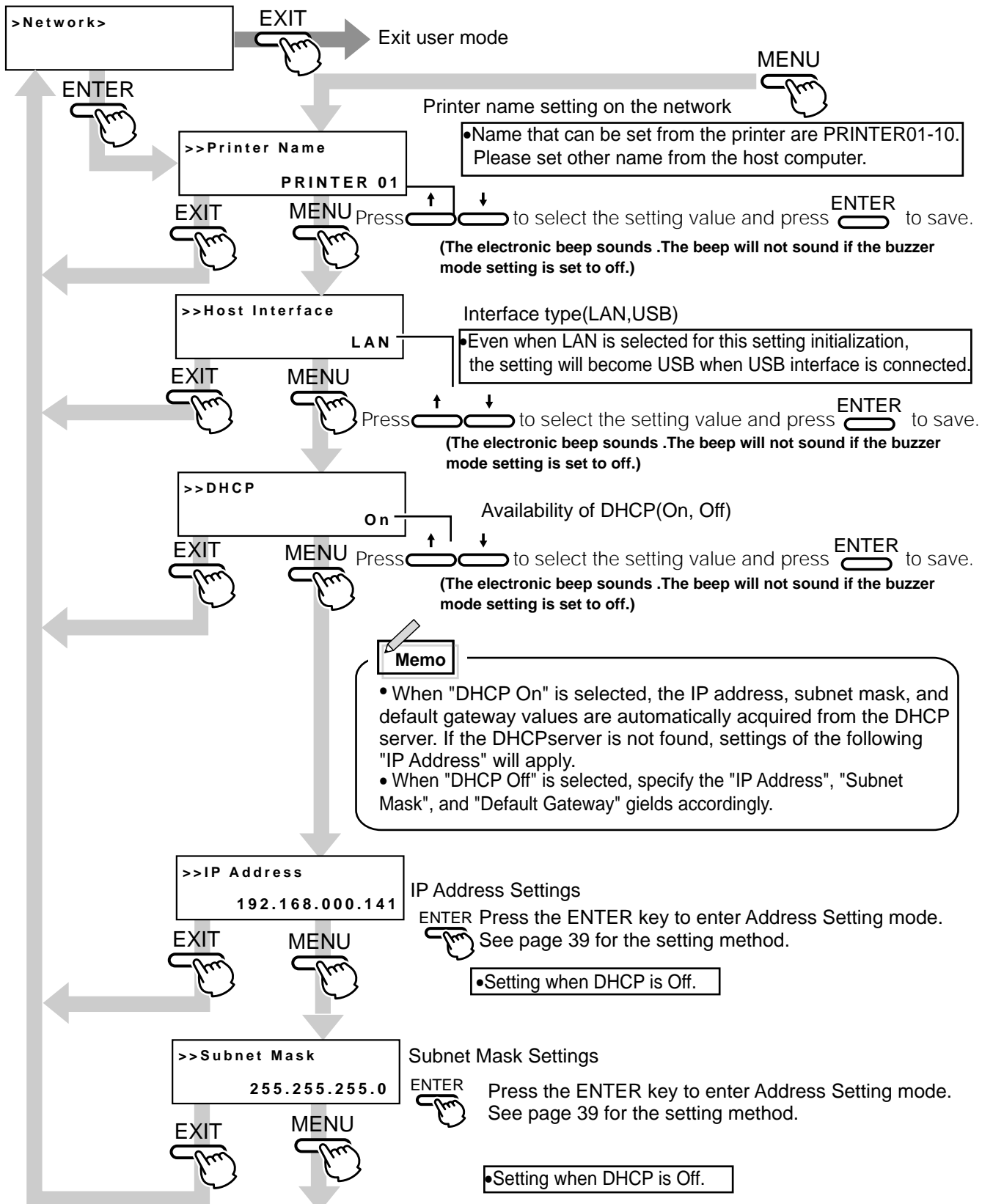

Continue on next page

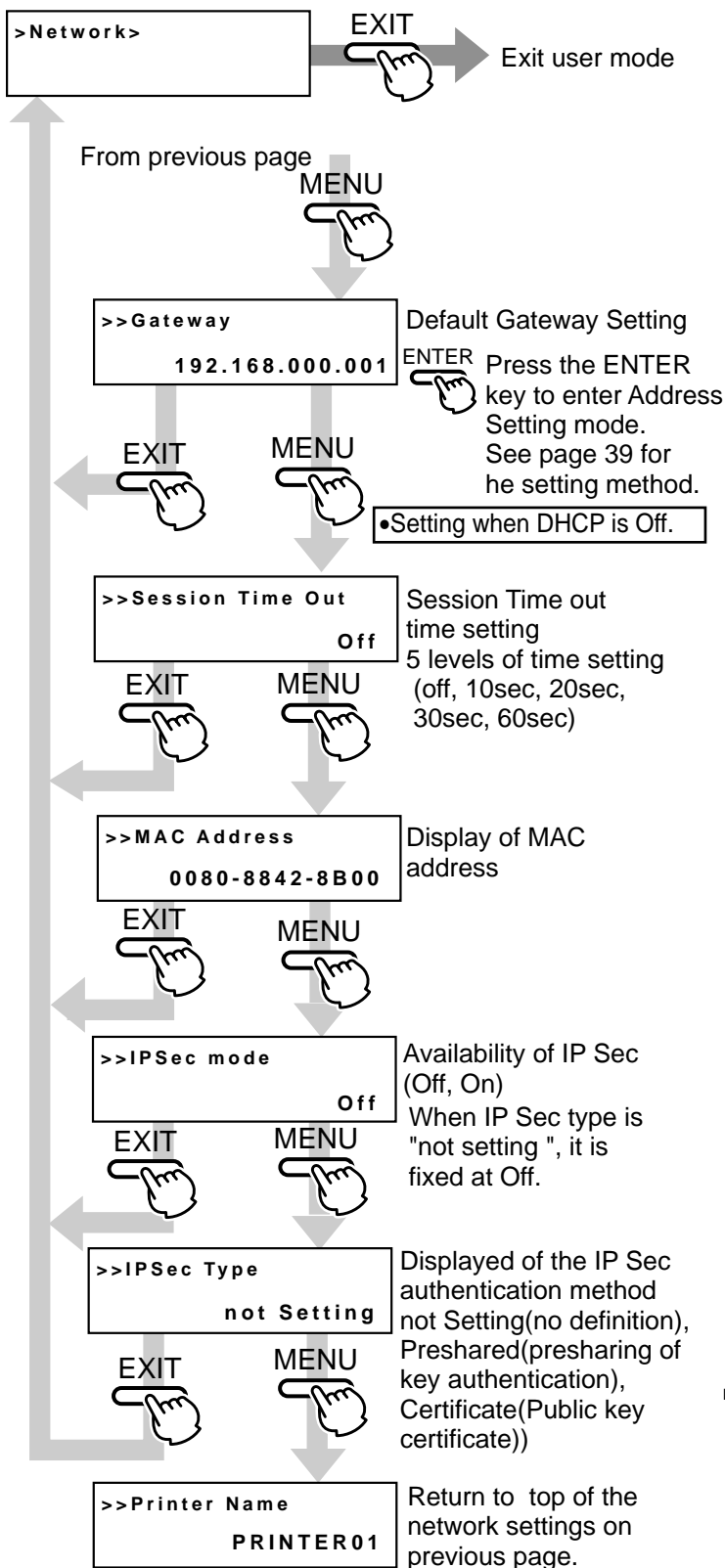

## Input method Address Setting mode

To enter IP Address, Subnet Mask and Default Gateway using Network Setting from the printer, press Enter key at each setting screen to go into the Address Setting mode. Use the following procedures to set the address.

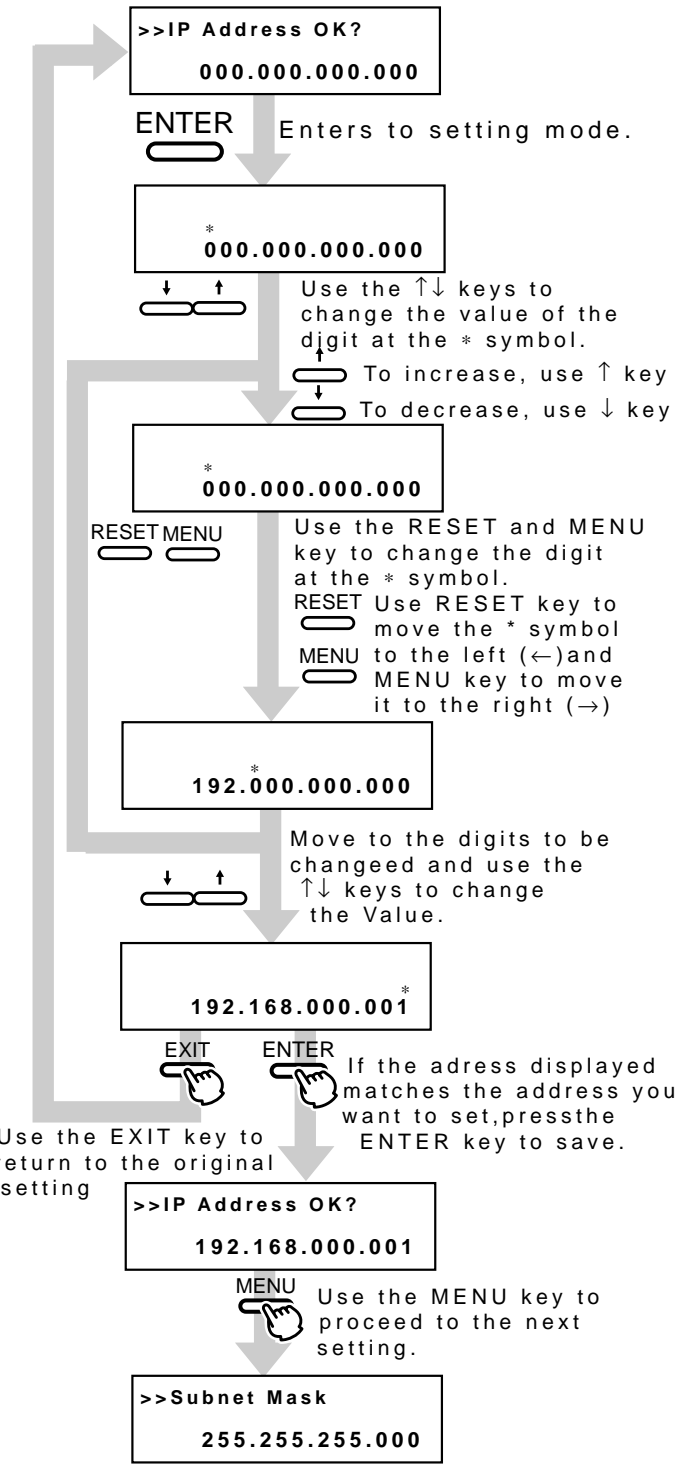

**CAUTION**  
Turn off the power then turn it on again to enable Network settings.

## Set position of MAC address print

In the case of UV print, MAC address must be printed at the edge of a card at the same time. Position of MAC address is selectable between Right Upper Edge or Left Bottom Edge via Command or operation panel. Please refer to following picture 1 about print position. Following mentioned coordinates are based on "Starting point of Print Area" and indicated in pixels.

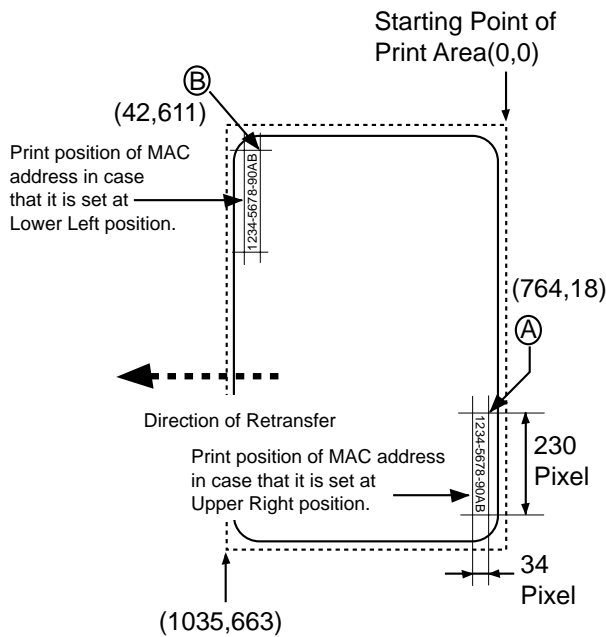

Fig. 1 Print Position of MAC address



### CAUTION

In case that UV is printed on YMC directly, print error will be occurred when retransferring. So in case that YMC image is overlapped with UV image, please print UV image on the retransfer film after YMC image is retransferred on the card. It is requested to pay the same special attention for MAC address that is printed with UV ink.

So in case that MAC address print area with UV ink is overlapped with with YMC-K image, please print UV image on the retransfer film after YMC-K image is retransferred on the card.

## Low temperature stand-by mode setting

Please set ON normally in this mode. When the printer is set ON in this mode, the printer will become standby at low temperature of the retransfer heat roller after no printing motion for 30 minutes and over. The temperature of the heat roller will automatically get an original setting when next card printing command received. For that reason, it takes long time for 1st card compared with normal printing.

Availability of heat roller control at the re-transfer side.(on,off)



Press to select the setting press to save. (The electronic beep sounds .The beep will not sound if the buzzer mode setting is set to off.)

## DOWNLOAD mode setting

Set the printer to DOWNLOAD mode.



### CAUTION

When data is transferring from the host computer, "Downloading" will be displayed. If the power is turned off at this time, the printer firmware will crash and the printer cannot operate.

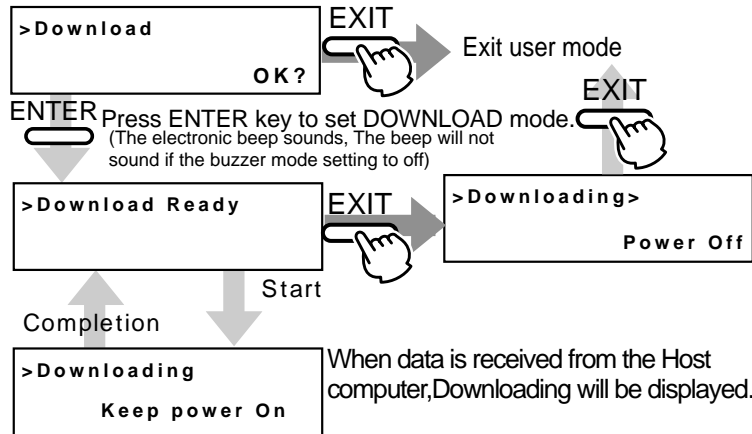

## Transport mode

To set the transport mode.

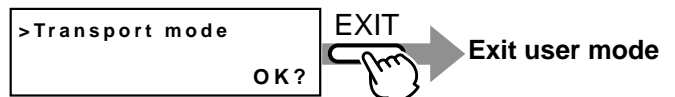

Press to carry out transport mode. (The electronic beep sounds.The beep will not sound if the buzzer mode setting is set to off.)

Please, Please turn off the power. Turning on the power, then the transport mode is canceled.



### CAUTION

When shipping or moving the printer, you must set the transport mode. If the printer is not set the transport mode, it may have a damage.

# Care and cleaning

Always make sure that the printer is turned off before cleaning.

(However, cleaning of the card feed rollers and magnetic head should be carried out with the power turned on.)

To achieve the best performance from the printer, always check each part before use for dust and dirt and clean if necessary.

The following explains the main rollers that require cleaning. For details about other rollers, see p.45 (Internal roller layout).

Dust and dirt, particularly on the thermal head, rollers and cleaning rollers can cause print blurs and shifting of colors.

## Cleaning the cleaning rollers

The cleaning rollers remove dust and dirt sticking to the card. Cleaning the cleaning rollers after every use is recommended if the printer is used almost everyday. Depending on the cards, there may be much dust and dirt. In such a case, perform cleaning every 100 to 200 cards. Do not do this, however, during printing operations.

### 1. Open the card tray.

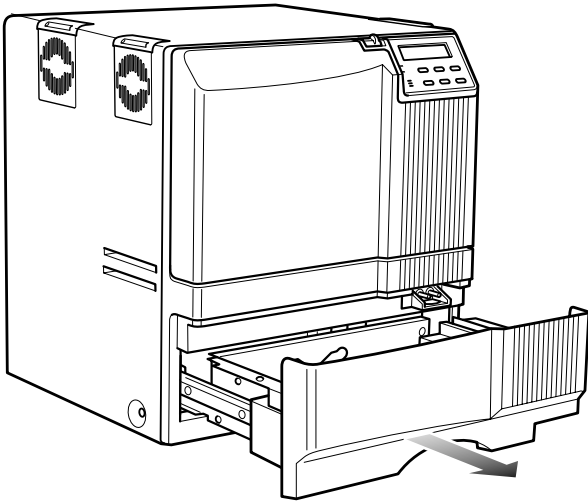

### 2. Remove the cleaning unit.

Pull out the cleaning unit toward you as shown in the illustration below.

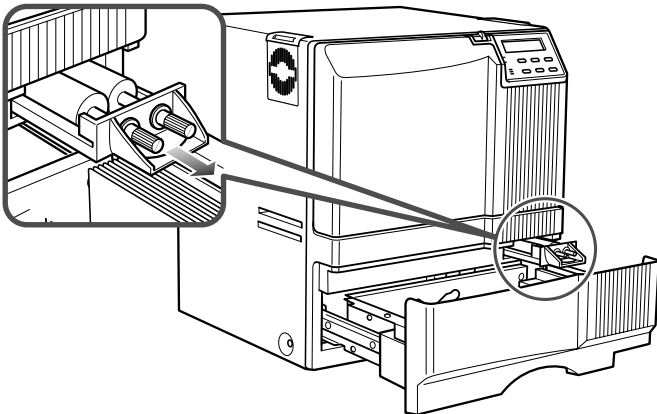

**CAUTION** When you remove the cleaning unit, be careful not to injure your fingers by inner mechanism.

### 3. Wash the rollers of the cleaning unit with water.

Wash out dirt on the roller surface with your fingers. Do not use alcohol or detergents. The cleaning unit should be cleaned only with running water.

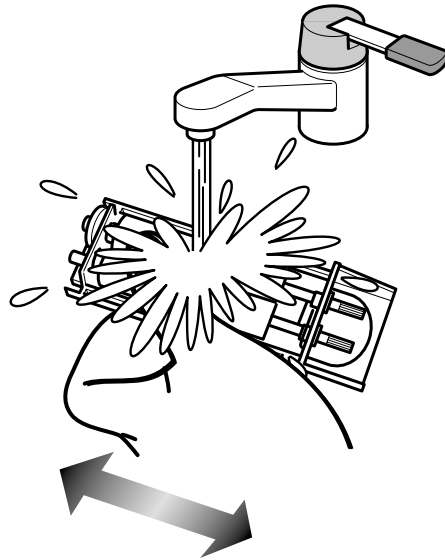

**CAUTION** After washing the cleaning unit with water, wait until it completely dries up and set it in the printer.

### 4. Push the cleaning unit back into the printer.

Push the cleaning unit with the rollers facing upward until it is securely back into the place.

### 5. Close the card tray.

**CAUTION** Deteriorated cleaning rollers may cause defects in the printed card. If the rollers begin to deteriorate, replace the cleaning unit. (We recommend replacement after a year)

## Cleaning the thermal head

When the thermal head gets dirty, defects such as unwanted lines appearing on the printed card may occur. It is recommended to clean the thermal head after printing about 10,000 frames. The thermal head is a consumable component, that is, it has a limited service life.

1. Open the printer door and remove the ink ribbon cassette and the retransfer film cassette.

See p.14, 16 in this manual.

2. Wipe the cleaning head with a cotton bud (sold separately), dipped in alcohol (sold separately).

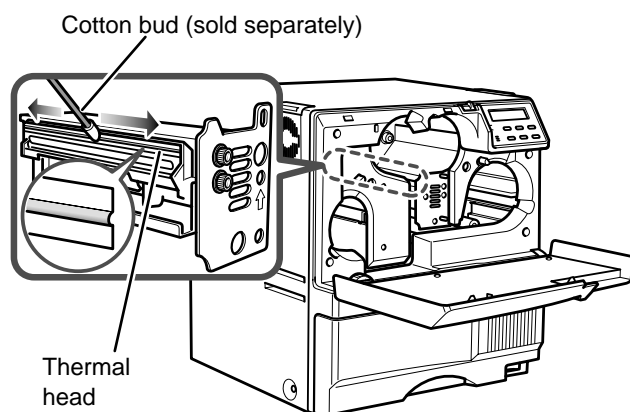

Wipe the head indicated with  horizontally.

3. Insert the ink ribbon cassette and the retransfer film cassette, then close the printer door.



### CAUTION

- The thermal head may break if touched with an electrostatic charge. Discharge yourself by touching the printer frame (metallic part) with your hands before cleaning the thermal head.
- Use a cotton bud soaked with absolute alcohol(ethanol). Be careful not to scratch the thermal head with hard materials like metal during cleaning.

## Cleaning the fan filter

When the fan filter gets dirty, partial omissions may occur on the printed cards, or the printing result looks dirty. It is recommended to clean the fan filter after printing about 10,000 cards.

1. Remove the fan filters located in three positions on the sides of the printer.

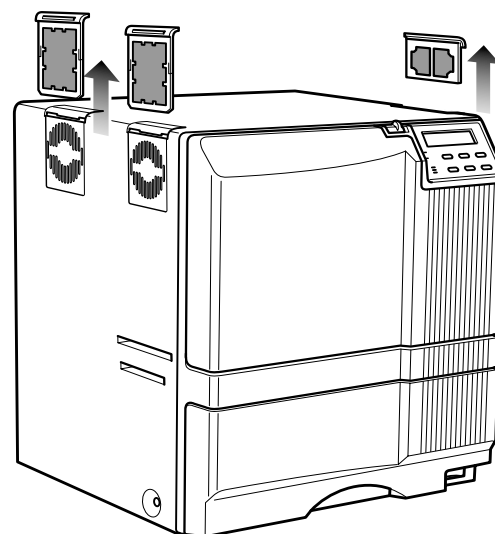

2. Remove the card tray.

See p.49 in this manual.

3. Remove the fan filter located on the base of the printer (inside the unit). Bring down the fan filter(side 2) while pressing its side (side 1). The fan filter can be taken out. Mount the fan filter by pressing this side.

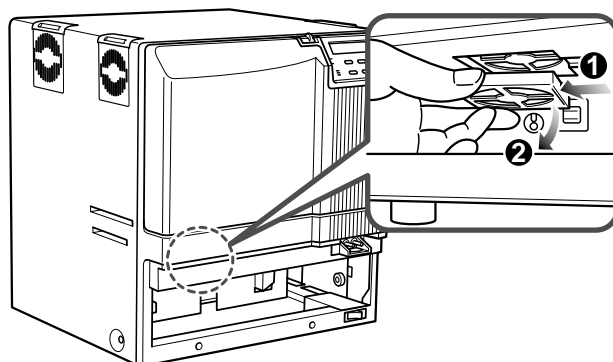

## Care and Cleaning (continued)

4. Remove dirt on the fan filter using a vacuum cleaner or other cleaning equipment. Hold the sponge with your hand so that it is not sucked into the cleaner.

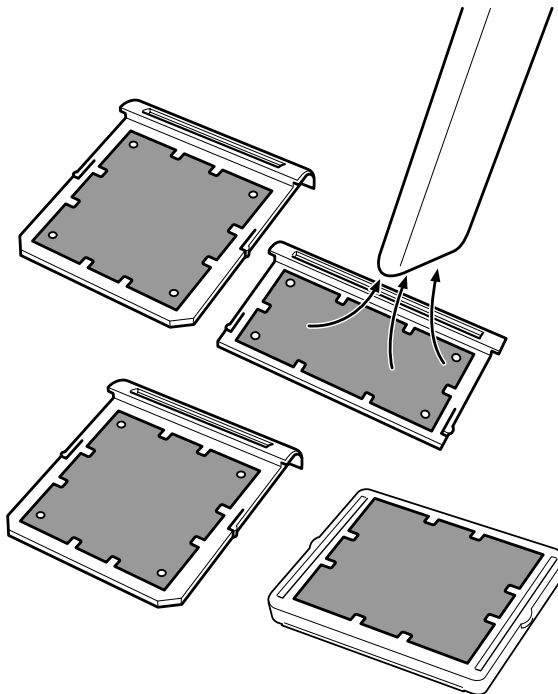

If the sponge is removed, attach it again as shown below.

### Side filter

Press down the sponge into the dents at four corners, and set it under the tabs on the frame.

### Bottom filter

Place the sponge under the tabs on the frame.

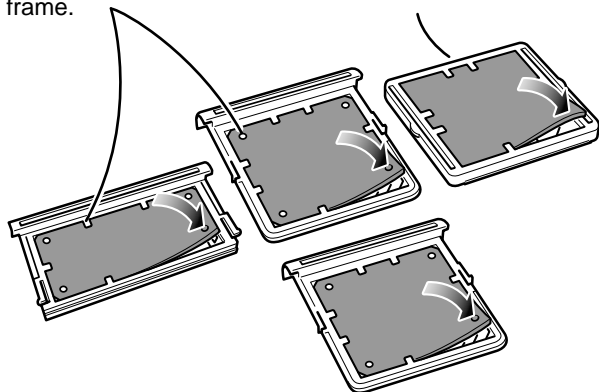

Replace the fan filter when it begins to deteriorate. (the elasticity of the sponge is lost and the sponge tends to be broken into pieces.) It is recommended that fan filter should be replaced once a year. Contact your dealer for details of replacing the filter.

5. Install the fan filters back to the original positions.

## Cleaning the card feed rollers and heat rollers

Dirty rollers are the major cause of jamming of the cards. It is recommended to clean the rollers once after printing about 1,000 cards. It is also recommended to carry out cleaning before the work, because the retransfer roller (heat roller) does not operate while it is hot.

1. Remove the retransfer film cassette.  
See p.16 in this manual.

2. Turn on the power of the printer.  
The printer initializes, and the [No Cassette] error is indicated.

3. From user mode select cleaning mode.

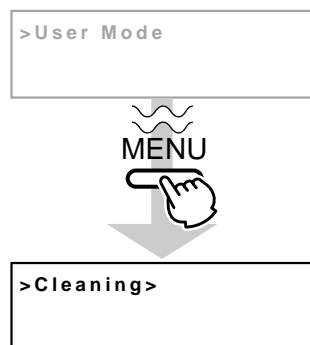

4. Press the ENTER button. Select [Rollers] with ↑ and ↓ buttons, and press the ENTER button.

See p.31 in this manual.

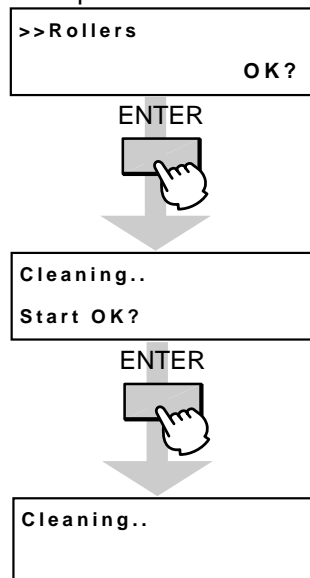

Insert the cleaning card in about 10 seconds. If you fails to set the card within this time, the printer returns to "Start OK?" Press the ENTER button again to proceed.

## 5. Set a cleaning card.

Peel off the protective paper of the cleaning card and insert it into the NG card discharge slot. The card will be drawn into the unit by the rollers and cleaning will then be carried out from card discharge slot on the left side of the printer. Insert the card with its adhesive face upside down to repeat the cleaning procedure once more.

Cleaning card (accessory)

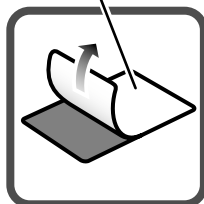
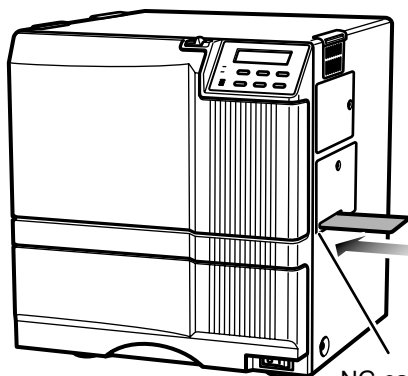

The cleaning card can be inserted only from the right side.

NG card discharge slot



### CAUTION

• If the retransfer roller (heat roller) gets too hot,

HR is too hot!

appears on the LCD panel, and the printer returns to the Ready state.

Turn off the power of the printer, and wait until the roller completely cools down before starting the work.

Confirm that the retransfer film cassette has been removed.

- The cleaning card does not go into the card discharge slot at the left side.
- If a card jam occurs, turn off the power, then turn on the power again. The jammed card will be discarded.

## 6. Turn off the power after the cleaning card is discharged.

Wait for 10 seconds before turning on the power again.



### CAUTION

The cleaning card can be used only once and disposable after using. If you use the dirty cleaning card many times, the dirt on the card moves onto the rollers, causing damages to the rollers. Consult your dealer for the cleaning card.

## Cleaning the magnetic head

Dirty magnetic head will cause a write/read error. It is recommended to clean the magnetic head after printing about 1,000 cards. Cleaning the magnetic head is not necessary if the magnetic stripe card is not used.

1. Keep the ink ribbon and retransfer film cassettes in their mounting positions.

2. Confirm that the READY LED (Green) is lighted

3. Specify the "cleaning" mode in the user mode.

See p.31 in this manual.

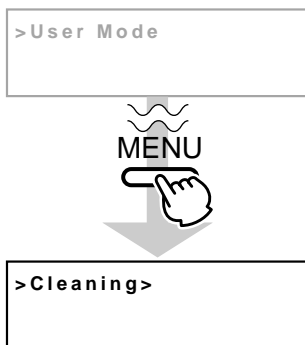

4. Apply alcohol on the magnetic head cleaning card. Drip three or four drops of alcohol on the magnetic stripes.

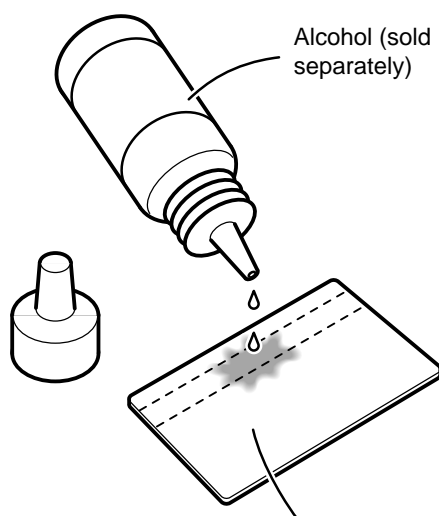

Magnetic head cleaning card (sold separately)

## Care and Cleaning (continued)

5. Set the card on the card tray.  
Place the card in right direction. See p.20.

6. Press the ENTER button, select "MG Head" with the ↑ or ↓ button, and press the ENTER button.

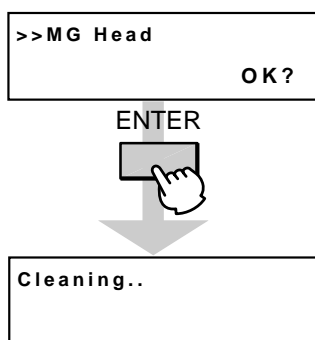

7. When the cleaning card is discharged from NG card discharge slot, turn off the power of the printer. Wait for 10 seconds before turning on the power again.



### CAUTION

Replace the magnetic head cleaning card when it gets dirty. A dirty card may pollute the head and cause damages to the head. Consult your dealer on the alcohol and cleaning card.

## Cleaning of the bobbin holders

Dirt on the bobbin holders may appear on the card or the film, cause defects on the card. Clean the bobbins when replacing ink ribbon or retransfer film.

1. Remove the cassettes of ink ribbon and retransfer film.  
See p.14 and 16 of this manual.
2. Wipe 4 bobbin holders with "Kim-Wipe" soaked with absolute alcohol(ethanol)

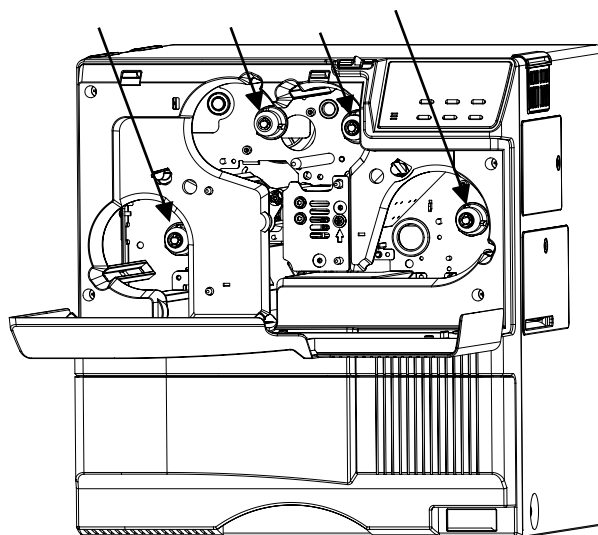

## Once printer servicing and cleaning have been completed

Once servicing and cleaning of the printer have been completed, check to make sure that all parts have been replaced properly.

Improper replacement of parts may result in the power not turning on or in operating errors.

## Periodical Maintenance

Periodical maintenance by the service personnel is recommended to avoid print error and failure. Consult your dealer for maintenance period and cost.

## Layout of rollers inside the printer

Below is a diagram of the layout of rollers inside the printer. Refer to this diagram in the event of card jams and when cleaning the rollers.

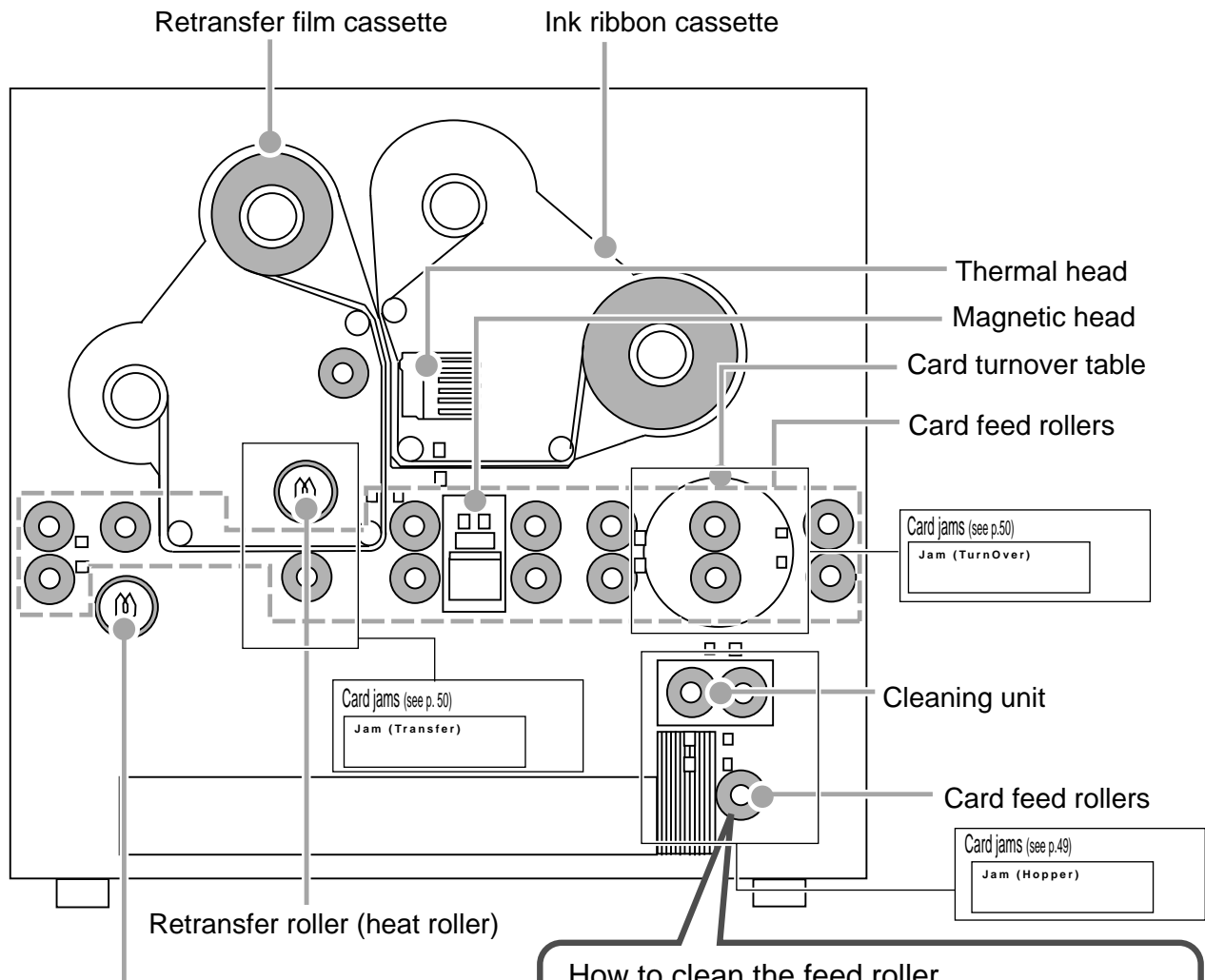

### How to clean the feed roller

1. Open the card tray, and take out the cards from the tray.
2. Move the card bracket until it locks.
3. Clean the feed roller with felt (sold separately) soaked with absolute alcohol(ethanol).

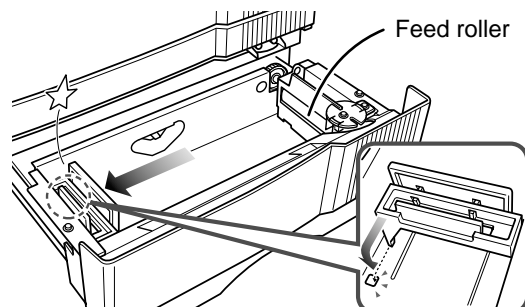







All rollers require routine cleaning.

- The card feed rollers, retransfer roller and bend remedial roller can be cleaned on cleaning mode.  
(See p.42, 43 in this manual.)
- The cleaning unit can be cleaned by water washing.  
(See p.40 in this manual.)

# Troubleshooting (continued)

## Error code listing

The meaning of “reset → enter buttons” in the list is, after pressing the Reset button, press the Enter button to initialize the unit.

Error code	Description of error	Remedy
Please, Power Off.	The power must be turned off so that the unit can be initialized.	Turn off the power and then on again.
Please Remove Media Cassette	The cleaning mode can not be set because there is a retransfer film in the unit.	Remove the retransfer film cassette, then press the “reset → enter buttons” and set the cleaning mode again.
HR is too hot.	The cleaning mode can not be set because the temperature of the heat roller is too high.	1. Turn off the power and allow about 20 minutes for the heat roller to cool. Then turn on the printer and set the cleaning mode again. 2. Confirm that the retransfer film cassette has been removed.
Jam (Hopper) 90	Card jam (hopper section)  See p.49	Turn off the power and remove cards from the hopper. Turn on the power.
Jam (TurnOver) 91	Card jam (turnover)  See p.50	Remove cards from the turnover section. Press the “reset → enter buttons” and initialize the unit.
Jam (MG) 92	Card jam (encode section)	Press the “reset → enter buttons” and initialize the unit. If no cards are discharged, turn off the power and remove the cards. Turn on the power.
Jam (Transfer) 93	Card jam (retansfer section)  See p.50	Turn off the power and remove the cards from the retransfer section. Turn on the power.
Jam (Discharge) 94	Card jam (card discharge section)	Turn off the power and remove the cards from the paper discharge section. Turn on the power.
Media Broken A0	The retransfer film has broken  See p.48	Mend the retransfer film. Press the “reset → enter buttons” and initialize the unit.
Media Search A1	Retransfer film search error	Reset the retransfer film. Press the “reset → enter buttons”. Call for service if the problem persists.
Media Run Out A2	The retransfer film has run out	Replace the retransfer film. Press the “reset → enter buttons” and initialize the unit.
Ink Broken B0	The ink ribbon has broken  See p.48	Mend the ink ribbon. Press the “reset → enter buttons” and initialize the unit.
Ink Search B1	Ink ribbon search error (RF-ID read error)	Reset the ink ribbon. Press the “reset → enter buttons” and call for service if the problem persists.
Ink Run Out B2	The ink ribbon has run out	Replace the ink ribbon. Press the “reset → enter buttons” and initialize the unit.
Turn Over Unit C0	Turnover mechanism error  See p.50	Press the “reset → enter buttons” and call for service if the problem persists.
Heater Cam C1	Heat roller operation error	Turn the power off and then on again. Call for service if the problem persists.
No Card	1. No card 2. The card tray is open or has been removed.	1. Replenish the cards. 2. Close the tray correctly.
Door Open D1	The printer door is open	Close the door. Press the “reset → enter buttons” and initialize the unit.
No Cleaning Ro. D7	Cleaning units missing	Attach the cleaning units. Press the “reset → enter buttons” and initialize the unit.
No Cassette D6	Cassette missing	Attach both the ink ribbon cassette and the retransfer film cassette. Press the “reset → enter buttons” and initialize the unit.

Should your printer require servicing, turn it off and unplug it and make inquiries at the outlet where it was purchased.

Error code	Description of error	Remedy
Hardware B8	Hardware error	Turn off the power and then on again. Call for service if the problem persists.
TR Overheat F0	Retransfer roller overheating	Turn off the power and then on again. Call for service if the problem persists.
TR Broken F1	Retransfer roller malfunction	Turn off the power and then on again. Call for service if the problem persists.
TR Sensor Broken F2	Retransfer roller thermister malfunction	Turn off the power and then on again. Call for service if the problem persists.
RR Overheat F3	Bend remedy roller overheating error	Turn off the power and then on again. Call for service if the problem persists.
RR Broken F4	Bend remedy roller malfunction	Turn off the power and then on again. Call for service if the problem persists.
RR Sensor Broken F5	Bend remedy roller thermister malfunction	Turn off the power and then on again. Call for service if the problem persists.
Overcool F6	Overcool	The usage environment temperature is too low. Use at the specified usage environment temperature. (Call for service if the problem persists.)
Head Overheat F8	Thermal head overheated	Turn off the power and leave the unit for about 10 minutes before switching on again. (Call for service if the problem persists.)
EEPROM Broken FA	EEPROM malfunction	Turn off the power and then on again. Call for service if the problem persists.
MG Unconnected A9	MG connection error	Turn off the power and then on again. Call for service if the problem persists.
MG Mechanical AB	MG mechanical error	Turn off the power and then on again. Call for service if the problem persists.
MG Hardware AC	MG hardware error	Turn off the power and then on again. Call for service if the problem persists.
MG Communicate AF	MG communication error	Check the I/F cable connected correctly. Turn off the power and then on again. Call for service if the problem persists.
EXT. Unconnected B9	Connected external device malfunctioning	Turn off the power and then on again. Call for service if the problem persists.
EXT. SW Setting BA	External device switch setting error	Turn off the power and then on again. Call for service if the problem persists.
EXT. Jam BB	External retransfer unit jam error	Press the "reset → enter buttons" and remove cards if they are not discharged. Press the "reset → enter buttons" and call for service if the problem persists.
EXT. Communicate BE	External unit communications error	Check the I/F cable connected correctly. Turn off the power and then on again. Call for service if the problem persists.
EXT2 Communicate BF	External unit2 communications error	Check the I/F cable connected correctly. Turn off the power and then on again. Call for service if the problem persists.
Hardware 44	Hardware error	Turn off the power and then on again. Call for service if the problem persists.

# Troubleshooting (continued)

## Stopping when printing

The printer may stop with no error messages if some failure with the connection to the host computer occurs or the not proper ink ribbon is set. In this case, open and close the printer door at once, and then press "reset" and press "enter" to initialize the printer.

## Mending broken ink ribbon and retransfer film

If the ink ribbon or retransfer film is broken, mend it in the following procedures:

1. Trim neatly the end of broken portions with a pair of scissors.
2. Align both ends and apply the Scotch tape in the center of the aligned ends. Please do not discard the used ink ribbon or retransfer film on the winding side.
3. Turn the ink ribbon or retransfer film to the winding side with your hand until the mended portion is completely wound up.

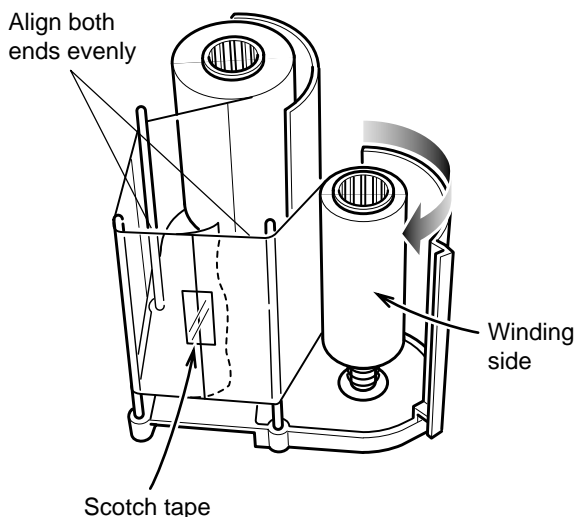

**CAUTION** Set the ink ribbon and retransfer film with care. See p.14 and p.16.

## About printing errors

If blurring or color shifts occur in your print results, clean all rollers starting with the cleaning rollers. Some image errors may depend on the design of the card to print. In particular, wrinkles can easily occur if large surfaces are printed with high density ink. To avoid such problems, contact the dealer where the printer was purchased concerning card designs.

## When retransfer operation is not complete

Depending on the cards used, retransfer operation may not be complete. In that case, try the following items. (See Page 33, "Retransfer mode setting")

1. Try to increase the retransfer temperature.
2. Try to decrease the retransfer speed. For the reverse side of the card, try to decrease the reverse retransfer speed.
3. Dust on the card surface. Use clean cards with no dust. Use the attached gloves to avoid finger mark on cards.
4. Ambient temperature

Retransfer operation may not be complete if the temperature of card surface is very low such as the card first printed in the cold morning. In that case, wait until the room becomes warm enough.

## Caution when printing characters

When printing small characters or thin lines in black ink, the thickness of minimum 2 dots necessary for "Standard" mode. Printing small characters or thin lines by 1 dot tends to cause blurring. To avoid this tendency, following settings are recommended. See "Ink mode setting" on Page 32.

1. Set the black value K:  
Try to increase setting value to more than 0 (Standard) Then darker printing is possible.
2. Set the K printing mode:  
Change mode from "Standard" to "Fine".  
Then thicker printing is possible.

If blurring still appears after having tried the above setting, selecting more adequate character font is recommended.

## Removing card jams

To determine the part of the machine affected by a card jam refer to the error code on the operation panel LCD panel on the printer and the relevant page in this manual.

When removing a jammed card, make sure that the printer is turned off before carrying out the following procedure.

### Hopper jam

#### 1. Pull out the card tray.

To remove the card tray, pull it out toward you until it no longer moves and lift it.

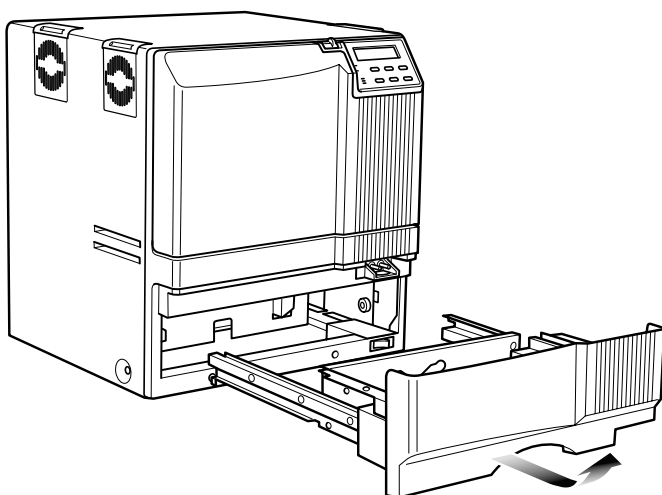

#### 2. Remove the jammed cards.

If you can hold the jammed card, pull it out.

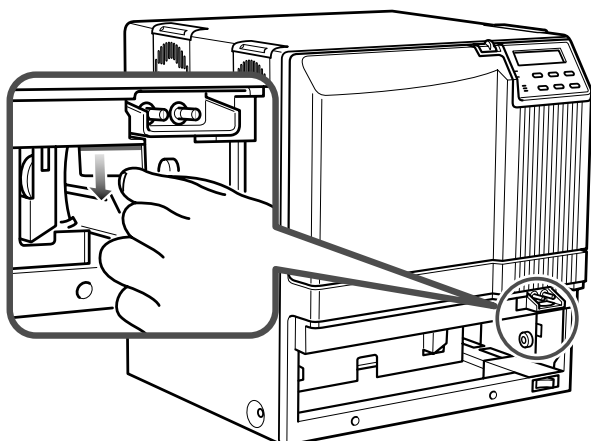

If you cannot hold the jammed card:  
Pull out a small portion of the cleaning unit.

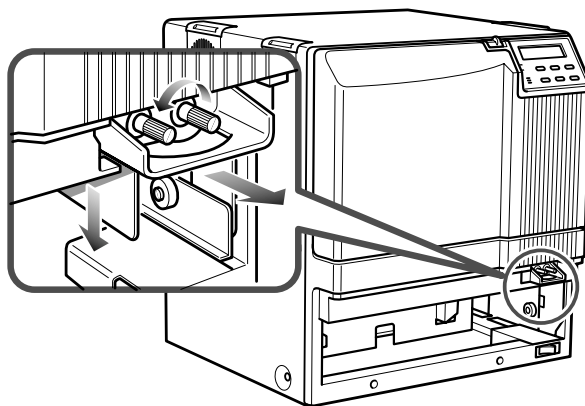

Turn the right knob to drop the jammed card. Remove the fallen card.

#### 3. Return the card tray to its original position. Push the card tray back into position on an angle.

Push the card tray back into its position while placing the card tray tabs on the folded over metal plates.

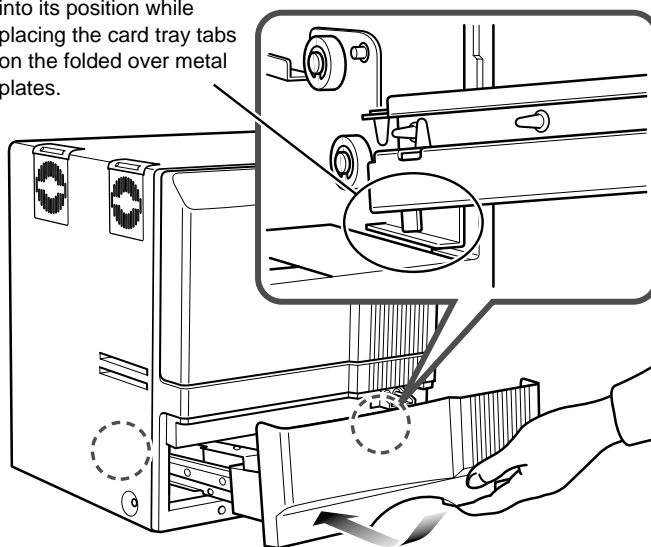

**CAUTION** Pushing the tray with excessive force may cause a failure of the printer.

# Troubleshooting (continued)

## Turnover section [Jam (turnover)]

1. Open the printer door and remove the ink ribbon cassette.

See p.14 in this manual.

2. Remove any jammed cards.

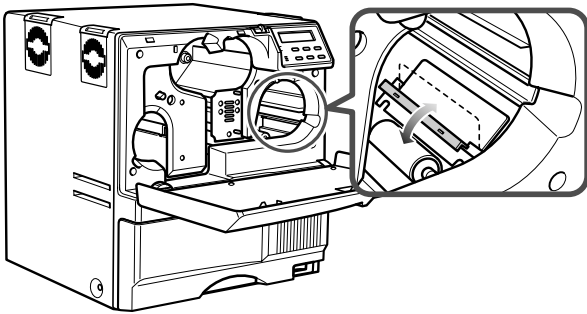

- If you can pull out the jammed cards, take them out.

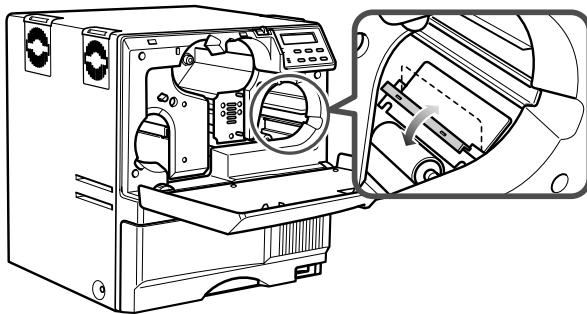

- If the jammed cards come out of the turnover table, push them back into the table, and rotate the table slowly (as it is positioned vertically) until the table is located so that the cards can be taken out.

### CAUTION



Injury

- When rotating the turnover table, be careful not to touch the metal edge. Wear a glove for this work.

## Retransfer section [Jam (transfer)]

1. Open the printer door and remove the retransfer film cassette.

See p.16 in this manual.

2. A jog lever are supplied as standard. The jog lever are attached to the center of the card tray

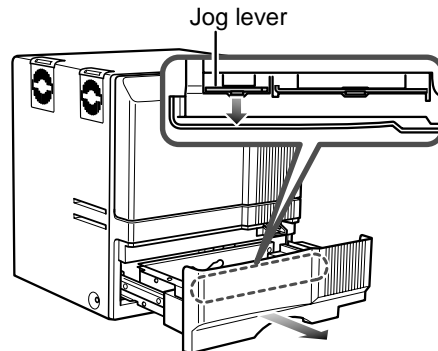

Turn the tabs in the arrow direction and take out the jog lever and removal stick.

3. Turn the jog dial to move the card to the position where it becomes visible.

Turn the jog dial with the attached jog lever.

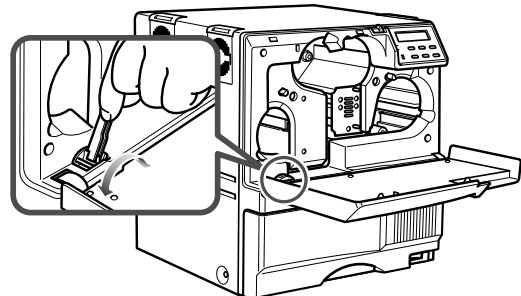

4. Remove the card.

Remove the card

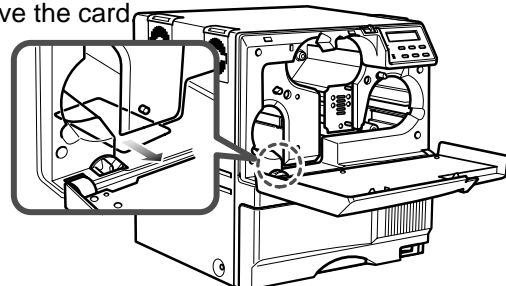

**CAUTION**

Some parts inside the printer may be hot. Be careful when removing the card.

## Main specifications

Recording method : Sublimation type retransfer  
 Feed format : Automatic feed  
 Recording density : 300 dpi  
 Expression gradation : 256 for Y, M, C and 2 for Bk

Interface : USB2.0(High-speed/ Full speed)  
 Ethernet(100BASE-Tx/10BASE-T)

Operating environment conditions  
 Temperature: 15°C ~ 30°C  
 Humidity: 35% ~ 70%  
 (no condensation)

Storage environment conditions  
 Temperature: -15°C ~ 55°C  
 Humidity: 20% ~ 80%

Power supply : 100~120ACV/220~240ACV  
 50/60 Hz (allowance±10%)

Current dissipation : 7.0A (for 100V system) / 5.0A  
 (for 200V system)

Wattage : 750W(Max.)

Mass : Standard 22kg  
 Excluding the built-in magnetic encoder

Dimension (cm) : 34.3(W) × 34.7(D) × 38.1(H)

Accessories : Power cord for 120ACV  
 (North America) ..... ×1  
 for 220~240ACV  
 (Europe) ..... ×1  
 Manual(English) ..... ×1  
 Cleaning card ..... ×1  
 Card stacker ..... ×1  
 Ink ribbon cassette ..... ×1  
 Retransfer film cassette ..... ×1  
 USB cable(200cm) ..... ×1  
 Jog lever (contained in the  
 card tray) ..... ×1  
 Gloves ..... ×1

### CF-32ICM (Medium-type IC unit)

Power supply : Fed from the printer.  
 Mass : 0.6kg  
 Dimension (cm) : 7.6(W) × 17.1(D) × 11.5(H)

### CX211CS Series (Compact IC unit)

Power supply : Fed from the printer.  
 Mass : 0.5kg  
 Dimension (cm) : 5(W) × 15.2(D) × 11.5(H)  
 Accessories : Screw (with washer) × 3  
 Screw (without washer) × 2

### Products sold separately

- Ink ribbon(YMCK)
  - 1,000 frames/set  
Model: DIC10216
- Ink ribbon(YMCKK)
  - 750 frames/set  
Model: DIC10217
- Ink ribbon(YMCKU)
  - 750 frames/set  
Model: DIC10313
- Retransfer film
  - 1000 frames/set  
Model: DIC10319

- Cleaning card  
10 cards/set  
Model: CX210-CC1

- Compact IC unit  
Non-contact IC encoder  
Model: CX211CS
- Medium-Type IC unit  
Non-contact IC encoder  
Model: CF-32ICM-D

The specifications and external appearance of this product are subject to change for improvements without a prior notice.

# Specifications (continued)

External appearance and dimensions

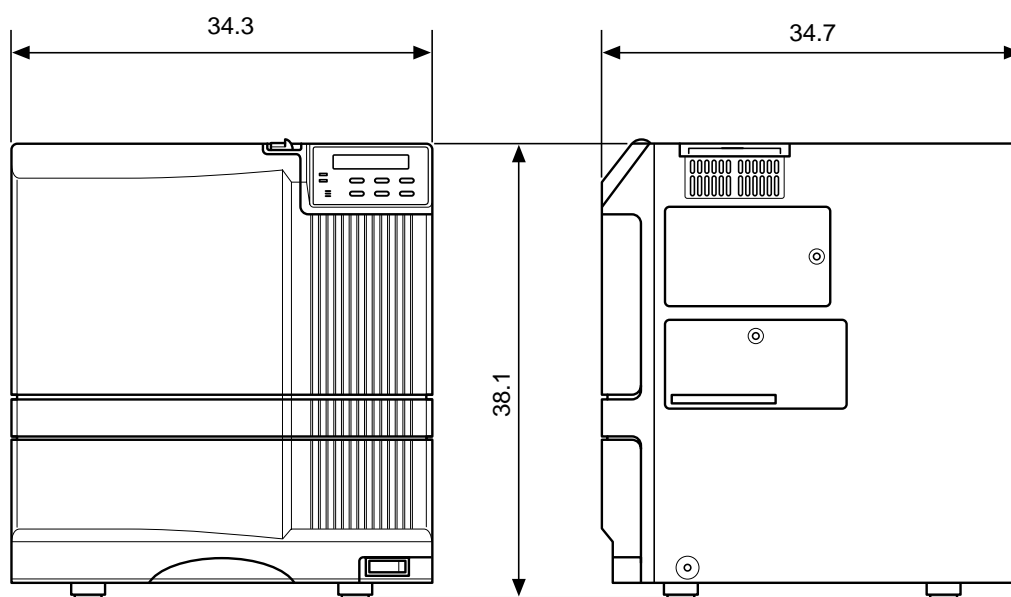

Front view

Side view

unit/cm

## In case of disposal

In case of disposal this unit, take care for compliance with the local law and regulations in your country.



**Ultra Electronics Card Systems**

Hampshire Road, Weymouth,  
Dorset DT4 9XD, United Kingdom

Tel: +44 (0) 1305 784 738

Fax: +44 (0) 1305 777 904

email: [UKsales@ultramagicard.com](mailto:UKsales@ultramagicard.com)



**Ultra Electronics Card Systems**

North American Sales & Support Center  
6711 - 176th Avenue NE Redmond WA 98052

Toll Free: 877 236 0933 Tel: (425) 556 9708

Fax: (425) 556 3962

email: [USsales@ultramagicard.com](mailto:USsales@ultramagicard.com)

**MAGICARD**

Secure ID card printers